

# Hammer

## User Manual

Translation

## Bandsaw N4400

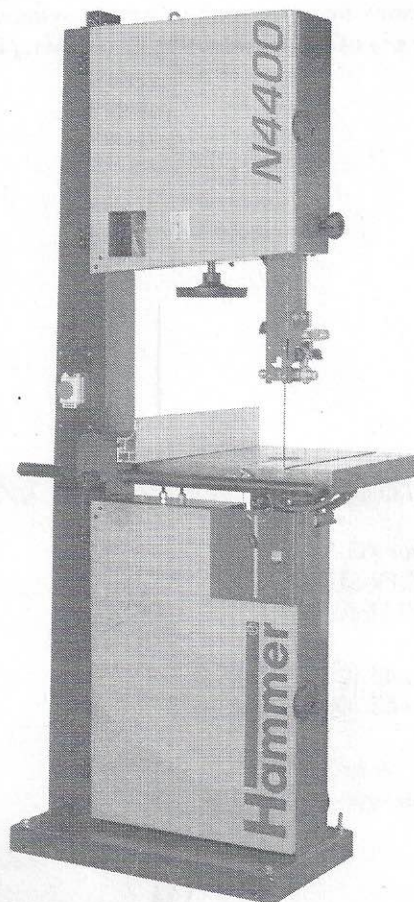

---

Keep this manual handy and in good condition for continual reference!



**Attention:** Upon arrival, the machine must be inspected immediately. If the machine was damaged during transport or if parts are missing, a written record of the problems must be submitted to the forwarding agent and a damage report must be drawn up. Be sure to also notify your supplier straight away.



For the safety of all personnel, it is necessary to conscientiously study this manual before assembling and putting the machine into operation. This manual must be kept in good condition, as it is considered to be a part of the machine. Furthermore, keep the manual handy in the vicinity of the machine so that it is accessible to personnel when they are using, maintaining or repairing the machine.

## HAMMER | A product of the FELDER GROUP

© Felder KG  
KR-FELDER-STR 1  
A-6060 Hall in Tirol

Tel.: +43 (0) 5223 45 0 90  
Fax.: +43 (0) 5223 45 0 99

E-Mail: [info@hammer.at](mailto:info@hammer.at)  
Internet: [www.hammer.at](http://www.hammer.at)

Table of contents

---

## Table of Contents

<b>1 General</b> .....	<b>5</b>
1.1 Explanations of the symbols.....	5
1.2 Information regarding the manual.....	5
1.3 Liability and warranty.....	6
1.4 Copyright.....	6
1.5 Warranty notice.....	6
1.6 Spare parts.....	6
1.7 Disposal.....	7
<b>2 Safety</b> .....	<b>8</b>
2.1 Intended use.....	8
2.2 Manual contents.....	8
2.3 Making changes and modifications to the machine.....	8
2.4 Responsibilities of the operator.....	9
2.5 What is required of the personnel.....	9
2.6 Work safety.....	9
2.7 Personal safety.....	10
2.8 Hazards arising from the machine.....	10
2.9 Other risks.....	10
<b>3 Declaration of Conformity</b> .....	<b>11</b>
<b>4 Technical data</b> .....	<b>12</b>
4.1 Dimensions and weight.....	12
4.2 Noise emission.....	12
4.3 Operation and storage conditions.....	13
4.4 Electrical connection.....	13
4.5 Dust extraction.....	14
<b>5. Setting up the machine</b> .....	<b>15</b>
5.1 Overview.....	15
5.2 Data plate.....	16
5.3 Automatic braking system.....	16
5.4 Brake system - USA model.....	16
<b>6 Setup and installation</b> .....	<b>17</b>
6.1 Safety instructions.....	17
6.2 Positioning.....	17
6.2.1 Setup and installation.....	18
6.2.2 Setting up the work table.....	18
6.2.3 Positioning the 90° end stop on the work table.....	19
6.2.4 Parallel cutting fence.....	19

<b>7 Operation.....</b>	<b>20</b>
7.1 Safety instructions.....	20
7.2 Switching on the machine / Switching off the machine.....	21
7.3 Saw blade replacement/tension.....	21
7.4 Authorised work techniques.....	22
7.4.1 Longitudinal cut along the marked line.....	22
7.4.2 Cutting round work-pieces in the transverse direction.....	22
7.4.3 Cutting work-pieces on the upright edge.....	22
7.4.4 Longitudinal cut of narrow or thin work-pieces with the guide fence.....	23
7.4.5 Angular cuts.....	23
7.4.6 Circular cuts.....	23
7.4.7 Diagonal cross cuts of rectangular work-pieces.....	24
7.5 Blade selection and maintenance.....	24
7.6 Adjusting the saw blade guide.....	25
7.6.1 Upper blade guide.....	25
7.6.2 Lower blade guide.....	25
<b>8. Maintenance.....</b>	<b>26</b>
8.1 Safety instructions.....	26
8.2 Cleaning and lubrication.....	26
8.3 Drive belts.....	27
8.3.1 Adjusting the belt tension.....	27
<b>9 Faults.....</b>	<b>28</b>
9.1 Safety instructions.....	28
9.2 What to do in case of a fault.....	28
9.3 What to do after rectifying the fault.....	28
9.4 Faults, causes and repairs.....	29
<b>10 Circuit diagrams.....</b>	<b>29</b>
10.1 Circuit diagram 1x 230 V.....	30
10.2 Circuit diagram 3x 400 V.....	31
<b>11 Spare parts.....</b>	<b>32</b>
11.1 Machine base-frame.....	32
11.2 Machine table.....	33
11.3 Height adjustable protection device.....	34
11.4 Upper wheel.....	35
11.5 Lower wheel.....	36
11.6 Safety equipment.....	37
<b>12 Index.....</b>	<b>38</b>

## General

---

## 1 General

### 1.1 Explanations of the symbols

Important technical safety instructions in this manual are marked with symbols. These instructions for work safety must be followed. In all

these particular cases, special attention must be paid in order to avoid accidents, injury to persons or material damage.



**Warning: Risk of injury or death!**

This symbol marks instructions that must be followed in order to avoid harm to one's health, injuries, permanent impairment or death.



**Warning: Danger – electric current!**

This symbol warns of potentially dangerous situations related to electric current. Not observing the safety instructions increases the risk of serious injury or death. Required electrical repairs may only be carried out by a trained electrical technician.



**Attention: Risk of material damage!**

This symbol marks instructions which, if not observed, may lead to material damage, functional failures and/or machine breakdown.



**Attention:**

This symbol marks tips and information which should be observed to ensure efficient and failure-free operation of the machine.

### 1.2 Information regarding the manual

This manual describes how to operate the machine properly and safely. Be sure to follow the safety tips and instructions stated herein as well as any local accident prevention directives and general safety regulations. Before beginning any work on the machine, ensure that the manual, in particular the chapter entitled „Safety“ and the respective safety guidelines, has been read in its

entirety and fully understood. This manual is an integral part of the machine; therefore, it must be kept in the vicinity of the machine and accessible at all times. If the machine is sold, rented, lent or otherwise transferred to another party, the manual must accompany the machine.

## 1.3 Liability and warranty

The contents and instructions in this manual were compiled in consideration of current regulations and state of the art technology as well as based on our know-how and experience acquired over many years. This manual must be read carefully before commencing any work on or with this machine. The manufacturer shall not be liable for damages and faults resulting from the disregard of instructions in the manual. The texts and images do not necessarily represent the delivery contents. The images and graphics are not depicted on a scale of 1:1. The

actual delivery contents are dependent on custom-build specifications, add-on options or recent technical modifications and may therefore deviate from the descriptions, instructions and images contained in the manual. Should any questions arise, please contact the manufacturer. We reserve the right to make technical modifications to the product in order to further improve user-friendliness and develop its functionality.

## 1.4 Copyright

This manual should be handled confidentially. It is designated solely for those persons who work on or with the machine. All descriptions, texts, drawings, photos and other depictions are protected by copyright and other commercial laws. Illegal use of the materials is punishable by law.

This manual – in its entirety or parts thereof – may not be transferred to third parties or copied in any way or

form, and its contents may not be used or otherwise communicated without the express written consent of the manufacturer.

Infringement on these rights may lead to a demand for compensation or other applicable claims. We reserve all rights in exercising commercial protection laws.

## 1.5 Warranty notice

The guarantee period is in accordance with national guidelines and details can be found within our website, [www.felder-group.com](http://www.felder-group.com)

## 1.6 Spare parts



**Attention: Employing counterfeit or faulty spare parts may lead to damage, malfunctions or complete breakdown of the machine.**

If unauthorized spare parts are installed in the machine, all warranty, service, compensation and liability claims against the manufacturer and their contractors, dealers

and representatives shall be rejected. Use only original spare parts from the manufacturer.



**Attention: A list of authorised original spare parts can be found at the end of this operating manual.**

## General

---

### 1.7 Disposal

If the machine is to be disposed of, separate the components into the various material groups in order to allow them to be reused or selectively disposed of. The whole structure is made of steel and can therefore be separated without any problem. This material is also easy to dispose of and does not pollute the environment

or jeopardise people's health. International environmental regulations and local disposal laws must always be complied with.



**Attention: Used electrical materials, electronic components, lubricants and other auxiliary substances must be treated as hazardous waste and may only be disposed of by specialized, licensed firms.**

## 2 Safety

At the time of its development and production, the machine was built in accordance with prevailing technological regulations and therefore conforms to industry safety standards.

However, hazards may arise should the machine be operated by untrained personnel, used improperly or employed for purposes other than those it was designed for. The chapter entitled „Safety“ offers an overview of all the important safety considerations necessary to optimise

safety and ensure the safe and trouble-free operation of the machine.

Additionally, in order to further minimize risks, the other chapters of this manual contain specific safety instructions, all marked with symbols. Besides the various instructions, there are a number of pictograms, signs and labels affixed to the machine that must also be heeded. These must be kept visible and readable and may not be removed.

### 2.1 Intended use

The N4400 bandsaw is solely for the use of sawing wood and other similar machinable materials. The machine should only be used to cut wood and wood-like panels. Operational safety is guaranteed only when the machine is used for the intended purposes.



**Attention:** Any other application above and beyond the intended purposes is considered improper use and is therefore not permitted. All claims regarding damage resulting from improper use that are made against the manufacturer and its authorized representatives shall be rejected. The operator shall be solely liable for any damage that results from improper use of the machine.

The term „proper use“ also refers to correctly observing the operating conditions as well as the specifications and instructions in this manual.

The machine may only be operated with parts and original accessories from the manufacturer.

### 2.2 Manual contents

All those appointed to work on or with the machine must have fully read and understood the manual before commencing any work. This requirement must be met even if the appointed person is familiar with the operation of such a machine or a similar one, or has been trained by the manufacturer. Knowledge about the contents of this manual is a prerequisite for protecting personnel

from hazards and avoiding mistakes so that the machine may be operated in a safe and trouble-free manner. It is recommended that the operator request proof from the personnel that the contents of the manual have in fact been read and understood.

### 2.3 Making changes and modifications to the machine

In order to minimize risks and to ensure optimal performance, it is strictly prohibited to alter, retrofit or modify the machine in any way without the express consent of the manufacturer. All the pictograms, signs and labels affixed to the machine must be kept visible, readable and

may not be removed. Pictograms, signs and labels that have become damaged or unreadable must be replaced promptly.



## **Safety**

---

### **2.4 Responsibilities of the operator**

This manual must be kept in the immediate vicinity of the machine and be accessible at all times to all persons working on or with the machine. The machine may only be operated if it is in proper working order and in safe condition. Every time before the machine is switched on, it must be inspected for visible defects and general intactness. All instructions in this manual must be strictly followed without reservation.

Besides the safety advice and instructions stated in this manual, it is necessary to consider and observe local accident prevention regulations, general safety regulations

as well as current environmental stipulations that apply to the operational range of the machine.

The operator and designated personnel are responsible for the trouble-free operation of the machine as well as for clearly establishing who is in charge of installing, servicing, maintaining and cleaning the machine. Machines, tools and accessories must be kept out of the reach of children.

### **2.5 What is required of the personnel**

Only authorized and trained personnel may work on and with the machine. The personnel must be briefed about all functions and potential dangers of the machine. „Specialist staff“ is a term that refers to those who – due to their professional training, know-how, experience, and knowledge of relevant regulations – are in a position to assess delegated tasks and recognise potential risks. If the personnel lack the necessary knowledge for working on or with the machine, they must first be trained. Responsibility for working with the machine (installation, service, maintenance, overhaul) must be clearly defined and strictly observed. Only those persons who can be expected to carry out their work reliably may be given permission to work on or with the machine. Personnel

must refrain from working in ways that could harm others, the environment or the machine itself. It is absolutely forbidden for persons who are under the influence of drugs, alcohol or reaction-impairing medication to work on or with the machine. When appointing personnel to work on the machine, it is necessary to observe all local regulations regarding age and professional status. The user is also responsible for ensuring that unauthorised persons remain at a safe distance from the machine. The personnel are obliged to immediately report to the operator any irregularities with the machine that might compromise safety.

### **2.6 Work safety**

Following the safety advice and instructions given in this manual can prevent bodily injury and material damage while working on and with the machine. Failure to observe these instructions can lead to bodily injury and damage to or destruction of the machine. Disregard of the safety advice and instructions given in this manual as

well as the accident prevention regulations and general safety regulations applicable to the operative range of the machine shall release the manufacturer and their authorised representatives from any and all liability and compensation claims.

## 2.7 Personal safety

When working on or with the machine, the following must be strictly observed:



**Persons with long hair who are not wearing a hairnet are not permitted to work on or with the machine.**

When working on or with the machine, the following must always be worn by personnel:



**Protective gear (overalls, safety goggles, dust mask, hairnet to contain long hair, etc.).**  
Sturdy, tight-fitting clothing (tear-resistant, no wide sleeves).



**Protective footwear**  
That protects the feet from heavy falling objects and prevents sliding on slippery floors.



**Ear protection**  
To protect against loss of hearing.

## 2.8 Hazards arising from the machine

The machine has undergone a hazards analysis. The design and construction of the machine are based on the results of this analysis and correspond to state-of-the-art technology.  
The machine is considered operationally safe when used

properly.  
Nevertheless, there are some residual risks that must be considered.  
The machine runs with high electrical voltage.



**Warning! Danger – electric current: Electrical energy can cause serious bodily injury. Damaged insulation materials or defective individual components can cause a life-threatening electrical shock.**

- Before carrying out any maintenance, cleaning and repair work, switch off the machine and secure it against being accidentally switched on again.
- When carrying out any work on the electrical equipment, ensure that the voltage supply is completely cut off.
- Do not remove any safety devices or alter them to put them out of commission.

## 2.9 Other risks

- Hearing damage as a result of high noise levels.
- Health impairments due to the inhalation of airborne particles, especially when working with beech and oak wood.

**Declaration of Conformity**

---

## 3 Declaration of Conformity



EG-Declaration of Conformity  
according to Machine Guidelines 2006/42/EG

We hereby declare that the machine indicated below, which corresponds to the design and construction of the model we placed on the market, conforms with the safety and health requirements as stated by the EC.

Manufacturer:	<b>Felder KG KR-FELDER-STR. 1 A-6060 Hall in Tirol</b>
Product designation:	<b>Bandsaw</b>
Make:	<b>HAMMER</b>
Model designation:	<b>N4400</b>
The following EC guidelines were applied:	<b>2006/42/EG 2006/95/EG 2004/108/EG</b>
The following harmonised norms were applied:	<b>EN 1807-1</b>

This EC Declaration of Conformity is valid only if the CE label has been affixed to the machine.

Modifying or altering the machine without the express written agreement of the manufacturer shall render the warranty null and void.

The signatory of this statement is the appointed agent for the compilation of the technical information

Hall in Tirol, 1.1.2010

Johann Felder, Managing Director FELDER KG  
KR-FELDER-STR. 1 • A-6060 Hall in Tirol

## 4 Technical data

### 4.1 Dimensions and weight

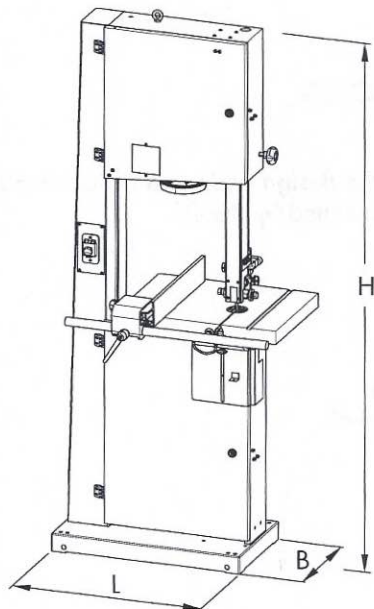

Fig. 4-1: Total size

#### Machine (L x W x H)

Total size	800 x 650 x 1900 mm
Package size	780 x 660 x 1900 mm
Net weight	140 kg

#### Bandsaw

Cutting height	315 mm
Rip capacity max.	420 mm
-  - Rip fence	370 mm
Saw blade length min.	3950 mm
Saw blade length max.	4000 mm
Saw blade width min.	6 mm
Saw blade width max.	25 mm
Saw blade speed	20 m/min
Wheel diameter	440 mm
Table size	420 x 575 mm
Tiltable table Left	0°
Tiltable table Right	45°

### 4.2 Noise emission

The given values are emission values and not safe workplace values. Although there is a correlation between emission and immission levels, it is not possible to state whether increased safety measures are required.

Factors which can considerably influence the present immission level at the workplace include the duration of exposure, the character of the work area and other influences in the neighbouring area.

Acceptable workplace values may also vary from country to country. However, this information should help the user to better assess the hazards and risks.

Depending on the installation location and other variables, the resulting noise emission can differ by up to 4 db (A) from the given values.

Type / Model	L Aeq	LW (A)	Lpc	
N4400	84,7 dB (A)	97,1 dBw(A)	5,1 mW	< 130 dB (A)

## Technical data

### 4.3 Operation and storage conditions

Operating/room temperature	+10 to +40 °C
Storage temperature	-10 to +50 °C

### 4.4 Electrical connection

	Alternating-current motor	Three-phase current motor
Motor voltage	1x 230 V	3x 400 V
Motor frequency	50/60 Hz	50/60 Hz
Motor power S <sub>6-40</sub> % <sup>*)</sup>	3 kW	3 kW
System of protection	IP 55	IP 55

<sup>\*)</sup> S<sub>6</sub> = operation under load and intermittent service; 40% = relative operating factor



**Attention! All operations may only be executed by an authorised electrical technician!**

The following electrical requirements must be fulfilled:

- Earth the machine using an electrical conductor.
- The voltage regulation in the electricity network must not exceed  $\pm 10\%$  of the rated voltage.
- The current supply has to be protected against damages e.g. armoured conduit.
- Connected vacuum hoses have to be earthed to avoid electrostatic charges.

The electrical connection may only be carried out by a competent and qualified person with the appropriate training.

Ensure that the mains supply is correct for the machine and use connecting cables with a cross-section appropriate to the power consumption of the drive motor.

The minimum conductor cable size is 2,5 mm for a 400V supply. If the mains voltage is 230V or has a rated current above 15 A, it is necessary to use higher capacity cabling.

Connect the 3 phases with the R-S-T clamps (L1-L2-L3) and the yellow-green electrical conductor with the earthing clamp (Pe).

When the machine is first switched on, check the rotational direction and if incorrect, exchange two phases in

the connection box.

The rotational direction of one phase motors has been set correctly by the manufacturer.

After connection, check that the connection box and cable gland have been screwed tightly.

The dust extractor has to be connected to the machine in such a way as to be operating automatically when the bandsaw is switched on.

An induction switch in the machine feed line will execute this function.

## 4.5 Dust extraction

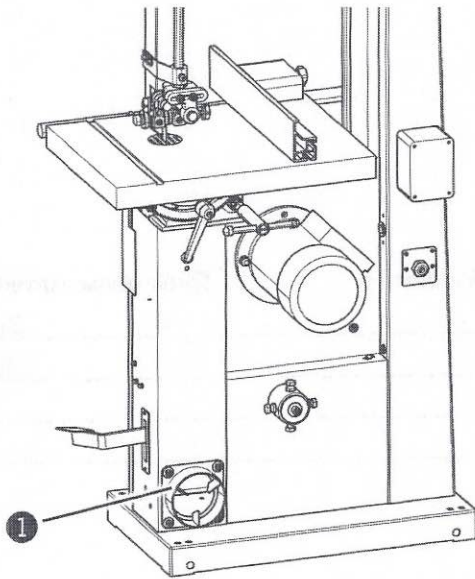

Fig. 4-2: Connection ports

The machine has to be connected to a dust extractor. The connection values and the position of the connection port are shown on the picture.

The air speed at the connection point has to be a minimum of 20 m/s for materials with a humidity less than 12 %.

The air speed should be increased to 25-28 m/s to extract dust from more humid materials (over 12 %).

Only flame resistant vacuum hoses can be used, conforming to DIN 4102 B1 and any other safety regulations in effect.

Vacuum connection-Ø	120 mm
Air speed	20 m/s
Min. depression	773 Pa
Volume flow min.	814 Cubic meters per hour.

① Connection ports 120 mm

## Setting up the machine

### 5. Setting up the machine

#### 5.1 Overview

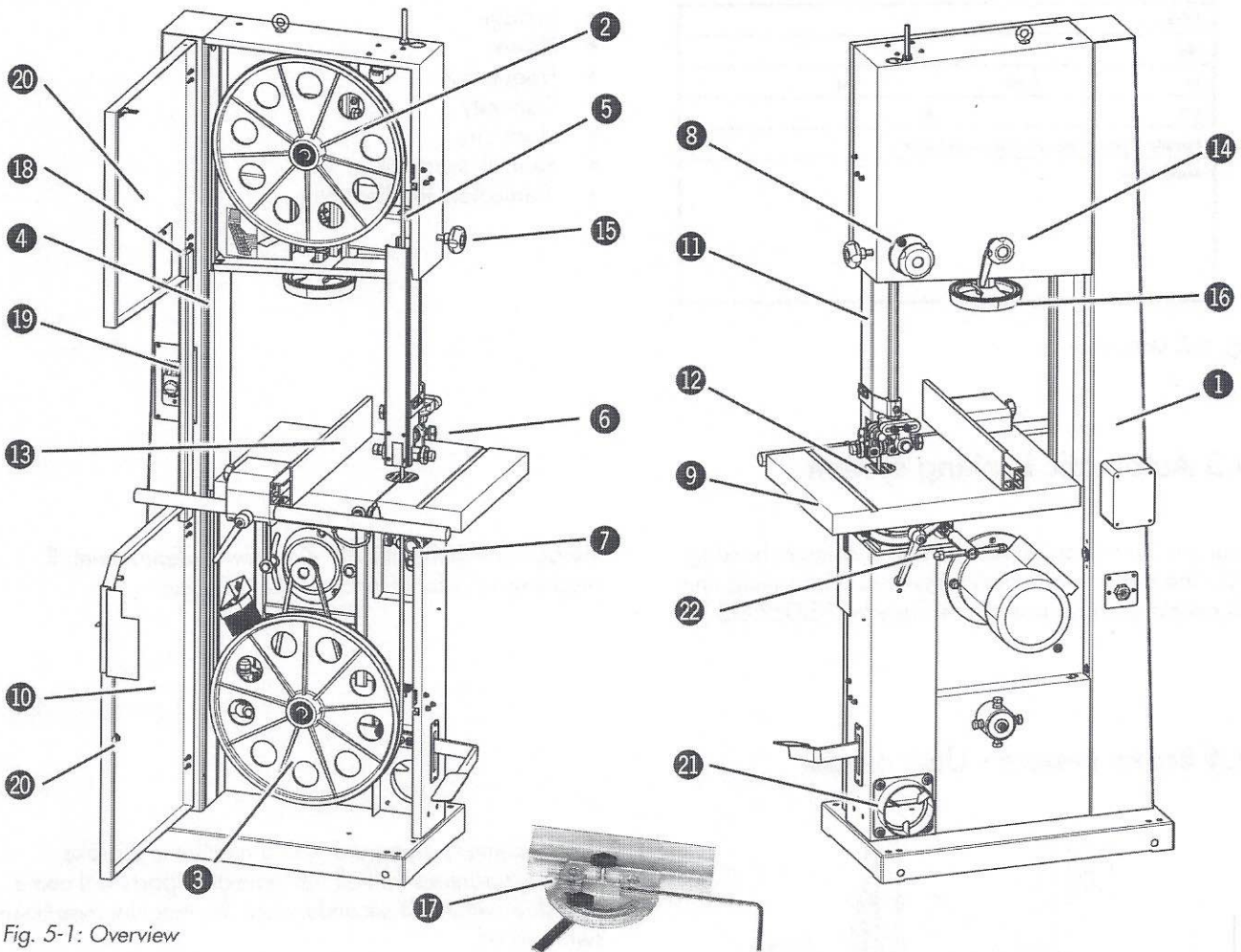

Fig. 5-1: Overview

- |                                       |  |
|---------------------------------------|--|
| ① Machine base-frame                  | ⑬ Guide fence  |
| ② Upper wheel                         | ⑭ Saw blade track - Adjuster hand wheel and clamping lever |
| ③ Lower wheel                         | ⑮ Lock wheel - Blade guide height adjustment               |
| ④ Rising part of saw blade            | ⑯ Blade tension hand wheel                                 |
| ⑤ Falling part of saw blade           | ⑰ Mitre fence (Accessories)                                |
| ⑥ Upper blade guide                   | ⑱ Saw blade tension indicator window                       |
| ⑦ Lower blade guide                   | ⑲ On/Off switch  |
| ⑧ Blade guide height adjustment       | ⑳ Lock wheel - Wheel door                                  |
| ⑨ Work bench                          | ㉑ Vacuum connector   |
| ⑩ Wheel door                          | ㉒ Tilttable<br>(Adjuster hand wheel and clamping lever)    |
| ⑪ Height adjustable protection device |  |
| ⑫ Table insert                        |  |

## 5.2 Data plate

KR-FELDER-STR.1 A - 6060 HALL in Tirol AUSTRIA Tel.: 0043 (0)5223 / 45 0 90 Fax.: 0043 (0)5223 / 45 0 99		<b>Hammer</b> <sup>®</sup> info@hammer.at / www.hammer.at	
TYPE :			
NR. :			
V:	PH:	HZ:	
KW:		A:	
Baujahr / year of constr. / annee de constr. :			
Motordaten:			

Fig. 5-2: Data plate

The data plate displays the following specifications:

- Manufacturer info
- Model designation
- Machine number
- Voltage
- Phases
- Frequency
- Capacity
- Electricity
- Year of construction
- Particulars for the motor

## 5.3 Automatic braking system

Your machine is equipped with an automatic braking unit. The brake is a maintenance-free DC braking unit. All necessary adjustments are done by FELDER KG.

Please contact the FELDER KG service department, if problems or a fault-function should occur!

## 5.4 Brake system - USA model

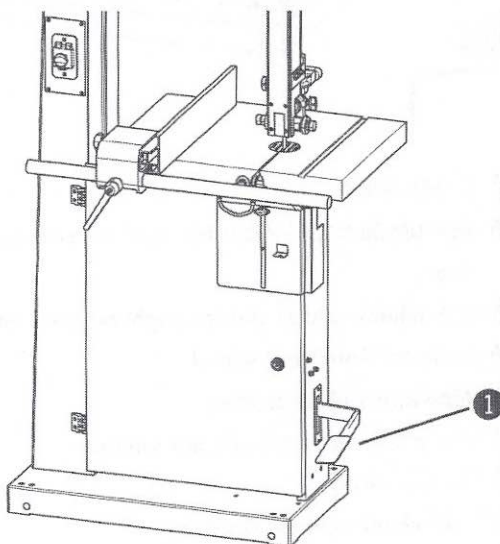

Fig. 5-3: Foot brake

The machine is equipped with a mechanical brake, which guarantees that all the moveable parts will come to a stop within 10 seconds, once the machine has been switched off.

The brake shoes of the brake will wear out and thus need to be controlled regularly and replaced if necessary to fulfill the required braking time, as stipulated in the regulations.

Please contact the FELDER KG service department, if problems or a fault-function should occur!

① Foot brake



## Setup and installation

## 6 Setup and installation

### 6.1 Safety instructions



**Warning! Risk of injury:** Improper assembly and installation can lead to serious bodily injury or equipment damage. For this reason these works may only be carried out by authorised, trained personnel who are familiar with the operation of the machine and in strict observance of all safety instructions.

- Ensure that there is sufficient space for working around the machine. Ensure there is ample distance between the machine and other solid constructions such as a wall or other machines.
- Keep the work area orderly and clean. Components and tools that are not fixed or have been left lying around may be the cause of accidents!
- Install the safety equipment according to the instructions and check that it functions properly.



**Warning! Danger – electric current:** Work on electrical fittings may only be carried out by qualified personnel and in strict observance of the safety instructions.

Before assembling and installing the machine, check to make sure it is complete and in good condition.



**Warning! Risk of injury:** An incomplete, faulty or damaged machine can lead to serious bodily injury or equipment damage. Assemble and install the machine and other units only if they are complete.



**Attention! Risk of material damage:** Only operate the machine in ambient temperatures from +10° to +40° C. If the instructions are not followed, damage may occur during storage.

### 6.2 Positioning

#### Characteristics of the installation site:

- Operation/room temperature: +10° to +40° C.
- Ensure that the work surface is sufficiently stable and has the proper load-bearing capacity.
- Provide sufficient light at the workstation.
- Ensure there is sufficient clearance to or shield neighbouring workstations.
- Risk of injury! Keep machines, tools and accessories etc. out of the reach of children.
- Vacuum hoses and electrical wires should be layed in such a way as to avoid tripping over them.

## 6.2.1 Setup and installation

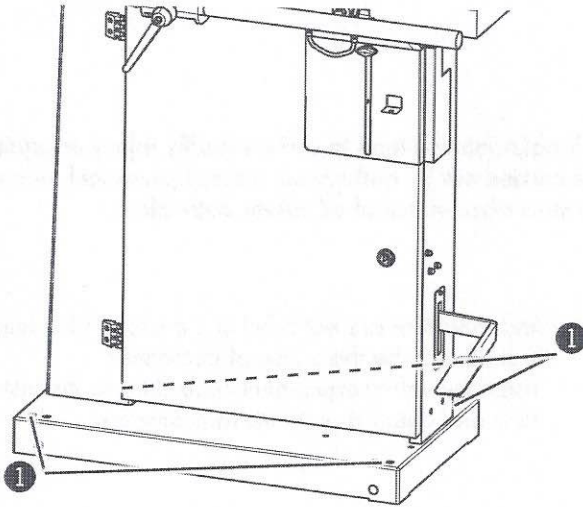

Fig. 6-1: Floor mounting

- ① Screws

The following points are important for a correct and efficient machine installation:

- The machine should be bolted to the floor with M10 screws for optimum stability, however take care not to overtighten the fastening bolts as this will increase vibrations. It is advisable to place vibration dampening pads between the floor and the machine.
- Install the machine in such a way as not to amplify the vibrations and machine noise.
- Ensure that workplace lighting is adequate.
- If the machine is to be installed between other machines, leave at least 80 cm distance in order to avoid collisions when cutting large work-pieces and to allow the use of equipment such as roll supports and additional tables.

## 6.2.2 Setting up the work table

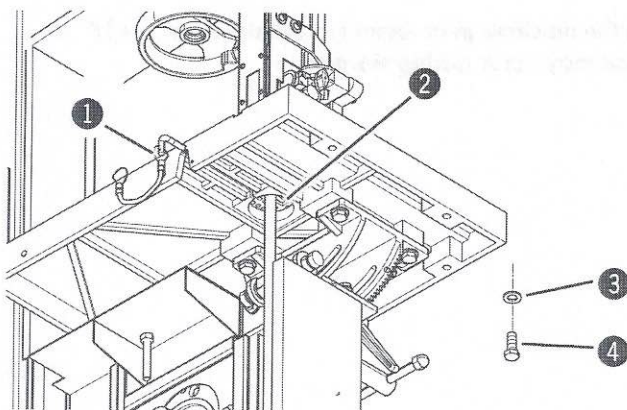

Fig. 6-2: Work table

- The table insert and positioning pin have to be removed to set up the work table.
- Thread the work table around the saw blade and mount to the machine using SKT screws and washers.
- Re-affix the table insert and positioning pin.

- ① Positioning pin
- ② Table insert
- ③ Washers
- ④ Screw

## Setup and installation

### 6.2.3 Positioning the 90° end stop on the work table

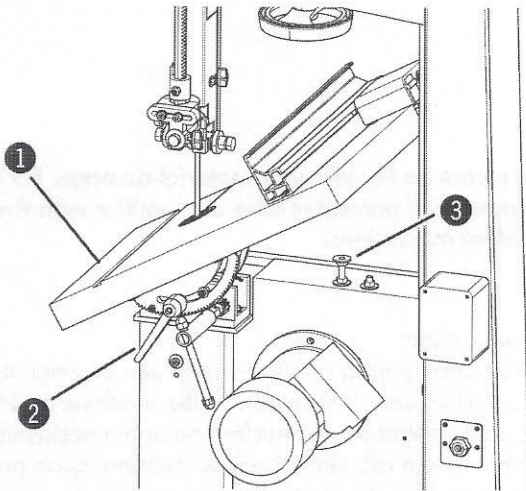

Fig. 6-3: End stop

- Disconnect the machine from the mains supply.
- Loosen clamping lever.
- Tilt the work table until it rests on the stop screw.
- Determine the exact angle using a 90° triangle.
- If the 90° in the initial position is not correct, adjust the stop screw accordingly.
- Check the 90° angle once the clamping lever is back in place.

- ① Work table
- ② Secure the clamping lever
- ③ Stop screw

### 6.2.4 Parallel cutting fence

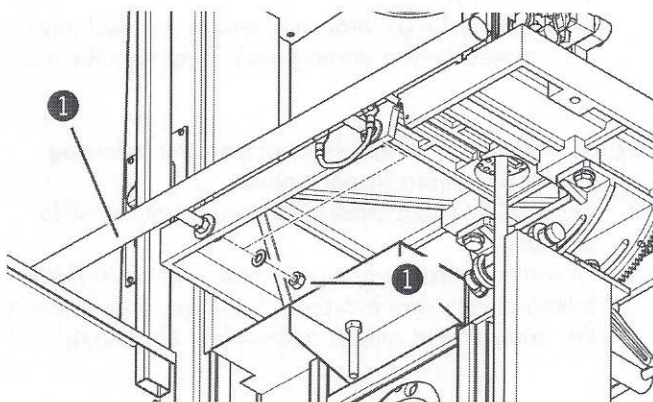

Fig. 6-4: Parallel cutting fence

- Use a nut to mount the fence rail to the machine table.
- Slide the premounted fence onto the track.

- ① Nut
- ② Fence rail

## 7 Operation

### 7.1 Safety instructions



**Warning: Risk of injury: Improper operation may lead to severe bodily injury or material damage. For this reason these works may only be carried out by authorised, trained personnel who are familiar with the operation of the machine and in strict observance of all safety instructions.**

#### Before starting work:

- Before assembling and installing the machine, check to make sure it is complete and in good condition.
- Ensure that there is sufficient space for working around the machine.
- Keep the work area orderly and clean. Components and tools that are not fixed or have been left lying around may be the cause of accidents!
- Ensure that all safety devices have been properly installed.
- Adjustments to the machine or tool replacement may only be conducted once the machine has stopped.
- Only clamp authorised tools to the machine.
- Install the vacuum system according to the instructions and test its function.
- Only process workpieces that can be safely placed on the machine and guided.
- Carefully inspect workpieces for foreign matter (nails, screws) which might impair processing.
- Support long work-pieces with additional surface equipment (e.g. Table extensions, Roll supports).
- Ensure that each unit is rotating in the proper direction.
- Keep tools for handling short and narrow workpieces close at hand.
- Before switching on the machine, always check to make sure that there are no other persons in the immediate vicinity of the machine.

#### During operation:

- When changing to another workpiece or when there is a malfunction, first switch off the machine and then secure it against being switched on again accidentally.
- Do not switch off, circumvent or decommission protective and safety devices during operation.
- Do not overload the machine! It is safer and performs better if operated within its power range.

#### When working on or with the machine, the following must be strictly observed:

- Persons with long hair who are not wearing a hairnet are not permitted to work on or with the machine.
- It is prohibited to wear gloves while working on or with the machine.  
All jewellery (rings, bracelets, necklaces, etc.) must be removed before starting work on or with the machine.

#### When working on or with the machine, the following must always be worn by personnel:

- Sturdy, tight-fitting clothing (tear-resistant, no wide sleeves).
- Protective footwear that protects the feet from heavy falling objects and prevents sliding on slippery floors.
- Ear protection to protect against loss of hearing.



**Attention: Risk of material damage: Only operate the machine in ambient temperatures from +10° to +40° C. If the instructions are not followed, damage may occur during storage.**



**Warning: Danger – electric current: Work on electrical fittings may only be carried out by qualified personnel and in strict observance of the safety instructions.**



**Attention! The machine will not start with the doors open and will automatically stop if doors are opened during operation. (Only valid for the CE-version !)**

## Operation

### 7.2 Switching on the machine / Switching off the machine



**Warning: Risk of injury due to insufficient preparation!**

It is only permitted to switch on the machine if, for the work at hand, the required preconditions are fulfilled and any preliminary work is completed. For this reason the instructions for adjusting, fitting and operating (see the corresponding chapters) must be read before switching on the machine.

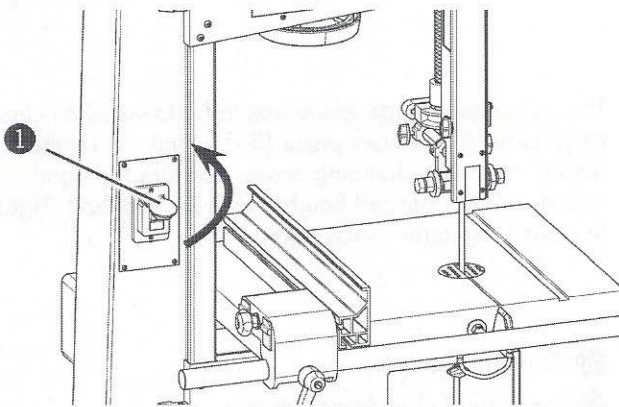

Fig. 7-1: On- and Off switch

The bandsaw has an On- and Off switch.

The switch has to be opened to be able to switch on the device.

If the switch lid is closed, then the machine is switched off automatically.

① Lid

### 7.3 Saw blade replacement/tension

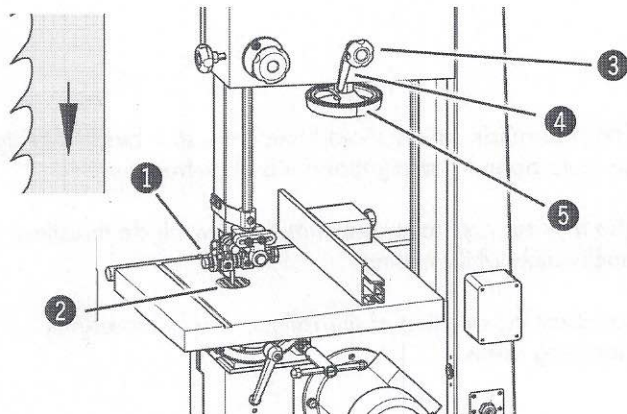

Fig. 7-2: Saw blade replacement

- Disconnect the machine from the mains supply.
- Remove table insert and positioning pin.
- Open wheel door.
- Unthread old blade through the machine table.
- Place new saw blade over both wheels (note the direction of the cut!).
- Release the clamping lever and using the hand wheel, set the saw blade track so that it lies in the centre of both wheels (thereby turning the wheels!) Close the clamping lever.
- Check the saw blade tension and if required, adjust with the hand wheel. The values refer to the saw blade width.

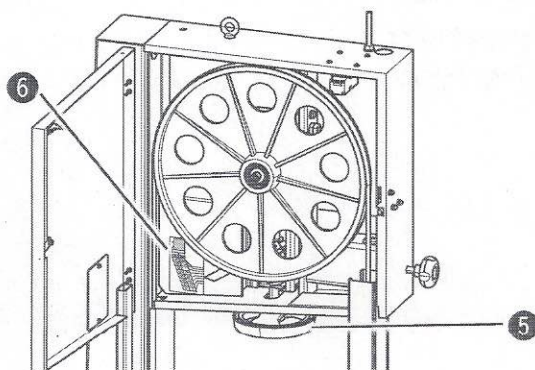

Fig. 7-3: Scale

- ① Positioning pin
- ② Table insert
- ③ Handwheel - Saw blade track
- ④ Clamping lever
- ⑤ Blade tension hand wheel
- ⑥ Scale

## 7.4 Adjusting the saw blade guide



**Warning! Risk of injury!**  
Do not change settings whilst the machine is in operation!

### 7.4.1 Height adjustable protection device

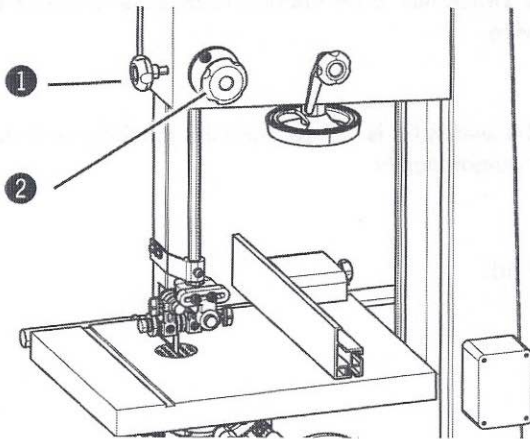

Fig. 7-4: Guide rollers

The upper saw blade guide has to be lowered as closely as possible to the work-piece (5–10 mm). To set the height, open the clamping screw and turn the hand wheel until the desired height has been reached. Tighten the clamping screw once again.

- ① Clamping screws
- ② Blade guide height adjustment

### 7.4.2 Saw blade guide up / down

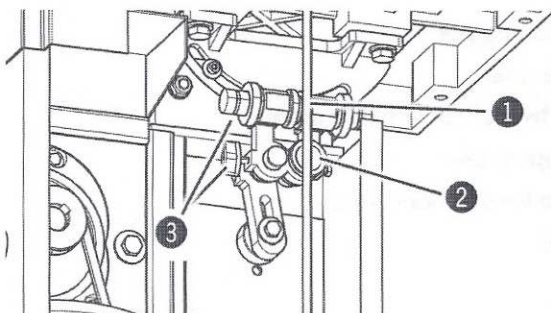
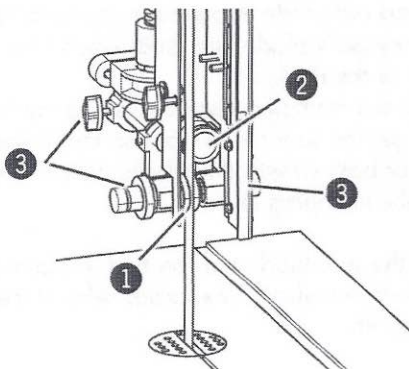

Fig. 7-5: Saw blade guide

The side guide rollers should touch the saw blade slightly so as to obtain a straight and vibration-free cut.

The rear support roller prevents the saw blade thrusting backwards whilst cutting.

To adjust the position of the rollers, simply loosen the clamping screw.

- ① Guide rollers
- ② Support roller
- ③ Clamping screw

## 7.5 Blade selection and maintenance

Selecting the type of saw blade and its width, depends on the material to be cut and the type of cut:

- Narrow saw blades are designed for curved and circular cuts, whereas wide saw blades are designed for straight cuts.
- A fine-toothed saw blade is required for hard wood, whereas a coarse-toothed saw blade is required for soft wood.

The gap between the individual teeth should be large enough to carry the material chips and to throw them away. If the gap is too small, the blade will overheat and rupture.

Do not use kinked, ruptured or bent saw blades.

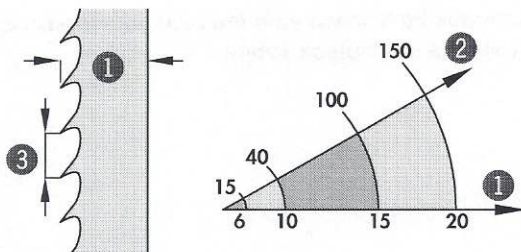

Fig. 7-6: Saw blades

- ① Blade width
- ② Radius cut
- ③ Tooth spacing

For soft wood, the set should be a max. of twice the thickness of the saw blade and for hard wood, a max. of 1.5 times the thickness of the saw blade.

Change blunt blades and have them sharpened by a specialist workshop or purchase a new saw blade.

It is recommended to use only high quality saw blades.

The following saw blades may be used:

Art. No.	Blade width	Tooth spacing
13.7.3406	6 mm	4 mm
13.7.3410	10 mm	6 mm
13.7.3415	16 mm	8 mm
13.7.3420	20 mm	8 mm
13.7.3425	25 mm	9 mm

## 7.6 Authorised work techniques

### 7.6.1 Longitudinal cut along the marked line

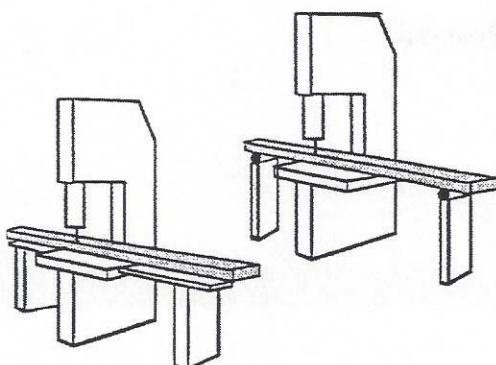

Fig. 7-7: Longitudinal cut

All uses which differ from the following work techniques have not been intended for this machine and are therefore not authorised.

Feed the work-piece with constant speed and pressure forwards without applying sideways pressure. Do not interrupt the cut and do not pull the work-piece backwards. When cutting large pieces, use appropriate table extensions or roll supports.

## 7.6.2 Cutting round work-pieces in the transverse direction

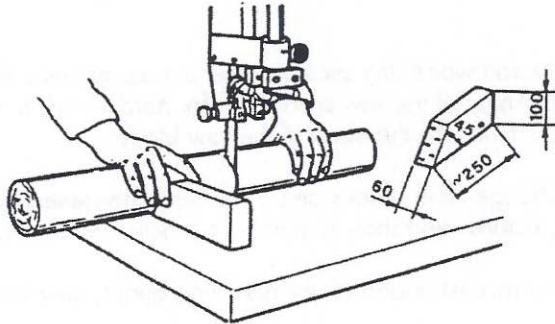

Fig. 7-8: Cutting a circular work-piece

Use an appropriate device with the minimum measurements as depicted in Fig. 12 to avoid the work-piece twisting during the cutting process.

## 7.6.3 Cutting work-pieces on the upright edge

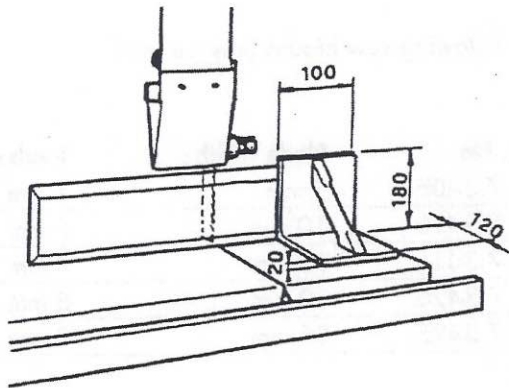

Fig. 7-9: Auxiliary fence

Use an auxiliary fence with the minimum measurements to guide the work-piece safely.

## 7.6.4 Longitudinal cut of narrow or thin work-pieces with the guide fence

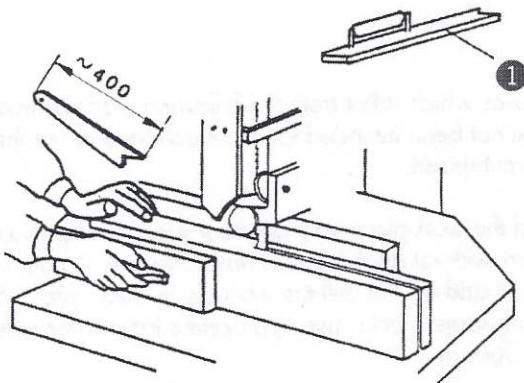

Fig. 7-10: Push stick

Use a push stick as depicted in Fig. 13 to prevent your hands from coming too close to the saw blade.

① Push stick



## Operation

### 7.6.5 Angular cuts

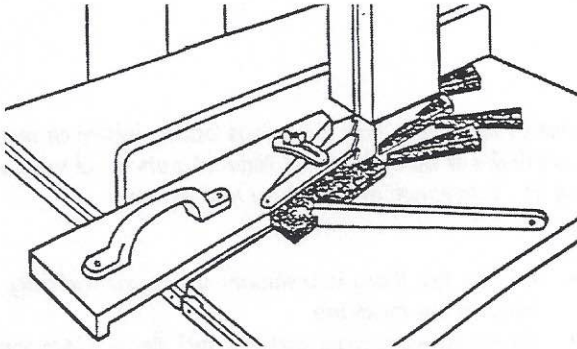

Fig. 7-11: Angular cuts

Use auxiliary equipment as depicted in the figure.

### 7.6.6 Circular cuts

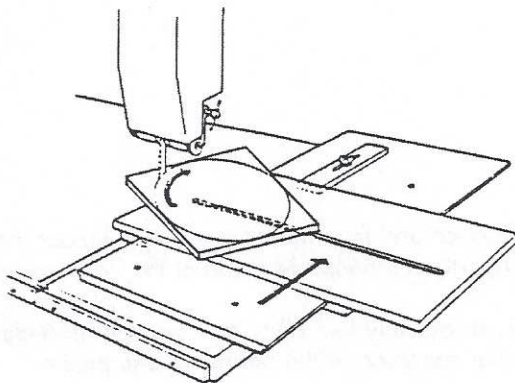

Fig. 7-12: Circular cuts

Use auxiliary equipment as depicted in the figure.

Accessories Order no.:  
01.0.300

### 7.6.7 Diagonal cross cuts of rectangular work-pieces

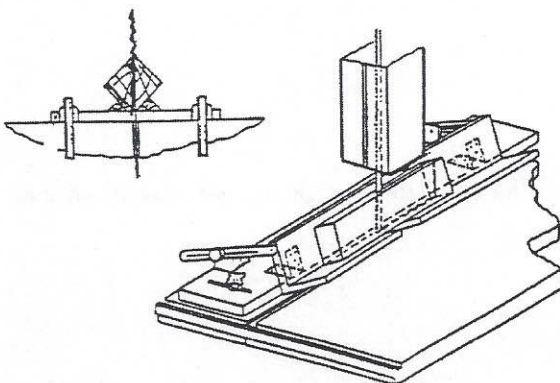

Fig. 7-13: Cross cut

Use auxiliary equipment as depicted in the figure.

## 8. Maintenance

### 8.1 Safety instructions



**Warning! Risk of injury: Improper adjustment and setup work can lead to serious bodily injury or material damage. For this reason these works may only be carried out by authorised, trained personnel who are familiar with the operation of the machine and in strict observance of all safety instructions.**

- Before beginning any maintenance work on the machine, switch off the machine and secure it against accidentally being turned on again.
- Before commencing any work with the machine, inspect it to ensure that it is complete and in technically good condition.
- Ensure that there is sufficient space for working around the machine.
- Keep the work area orderly and clean. Components and tools that are not fixed or have been left lying around may be the cause of accidents!
- Install the safety equipment according to the instructions and check that it functions properly.



**Warning! Danger – electric current: Work on electrical fittings may only be carried out by qualified personnel and in strict observance of the safety instructions.**

### 8.2 Cleaning and lubrication

- Regularly remove accumulated saw dust with a vacuum cleaner from the inside of the machine.
  - Remove accumulated resin and dust from bearing surfaces taking care not to damage the wheel operating surfaces.
  - The wheel bearings are sealed and do not require lubricating.
- oiled surface and this would for example hinder the gliding properties of the blade guide or the belt tension unit.
- Check periodically that all screws are tight and also check the condition of the protective equipment.

It is not necessary to lubricate other machine parts as the circulating saw dust will get caught on every greased or

### 8.3 Drive belts

Check periodically that all screws are tight and also check the condition of the protective equipment.

The drive belt tension must be rechecked after a few hours of use to correct slackening. To check the tension, press the belt inwards in the centre, using a load up to

3-4 kg. The belt deflection should not exceed 5-6 mm.

## Maintenance

### 8.3.1 Adjusting the belt tension

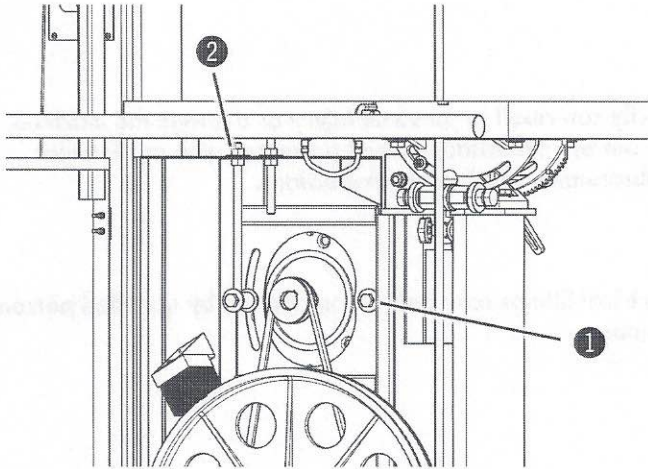

- Loosen nut.
- The tension of the belt can be adjusted by tightening or loosening the nut.
- Screw nut on again.

It is important that the belts are always correctly tensioned, as belts which are too loose will weaken the drive power and the impact of the brakes. Belts which are too tight will lead to overheating.

- ① Nut 1
- ② Nut 2

Fig. 8-1: Drive belts



**Attention! Risk of material damage! Do not over-tension the drive belt! Stop turning the belt-tensioning screw once the drive belt is tensioned sufficiently, enabling it to transmit power effectively.**

### 8.4 Direction of cut and parallelism

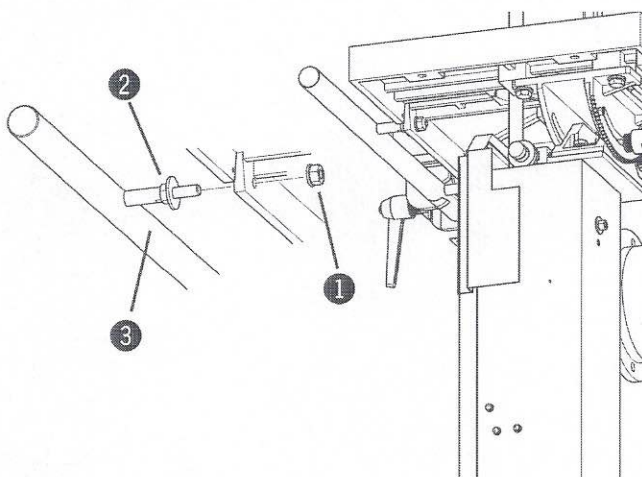

If the cut, using the longitudinal stop, is still not parallel, the following are possible causes:

- Incorrect saw belt grinding and set
- Insufficient saw belt tension
- Incorrect longitudinal stop setting in relation to the saw belt.

#### Set the fence plate (guide):

1. Loosen the lock nuts.
2. Correct the position with the slotted round nut if required.
3. Tighten the lock nuts.

- ① Lock nuts
- ② Adjusting nut
- ③ Fence plate

Fig. 8-2: Direction of cut and parallelism

## 9 Faults

### 9.1 Safety instructions



**Warning! Risk of injury:** Removing faults incorrectly can result in personal injury or damage the machine. For this reason these works may only be carried out by authorised, trained personnel who are familiar with the operation of the machine and in strict observance of all safety instructions.



**Warning! Danger – electric current:** Work on electrical fittings may only be carried out by qualified personnel and in strict observance of the safety instructions.

### 9.2 What to do in case of a fault

#### Strictly speaking:

- In the event of a breakdown which creates danger for either personell or equipment the machine should be stopped immediately using the emergency stop.
- Also disconnect machine from the mains and secure it from being started up.
- Inform those responsible of faults immediately.
- Type and extent of fault should be determined by an authorised professional, as well as the cause and repair.

### 9.3 What to do after rectifying the fault



**Warning! Risk of injury!**

#### Before switching the machine back on:

- The fault and its cause are professionally repaired.
- All safety measures have been installed according to regulations and are faultless.
- People are not located in the danger area of the machine.

## Faults

### 9.4 Faults, causes and repairs

Fault	Cause and problem elimination
Machine does not start	Safety break switches are breaking the electric circuit ⇒ Ensure that the side doors are closed properly
	Emergency stop switch engaged ⇒ Unlock the emergency stop switch
Squeaking noises when starting up	Insufficient tension (Drive belt) ⇒ Retensioning the drive belt
The cuts are not straight	Check sharpness and set of saw blade
	Check the guide fence alignment
The saw blade is torn at the base of the individual teeth	Incorrect sharpness and constant overheating, or otherwise incorrect set of saw blade
	Width of saw blade is too thick in relation to the diameter of the wheel
	Defect or soiled wheel running surfaces
	Incorrectly aligned wheels ⇒  Felder
The saw blade is rupturing on the rear side	Feed rate or pressure is too high during cutting
	Poor welded joint ⇒ Saw blade replacement
	The rear support roller of the saw blade guide is defective
The machine comes to a stillstand with the saw belt locked into the workpiece	Stop the motor and loosen the the brake. Enlarge the cutting gap with a wedge and remove the workpiece. Prior to switching the machine on again, check the condition of the saw belt and its position on the wheels
The saw belt is straying forwards and backwards	The belt is not aligned with the welded joints ⇒ Saw blade replacement
The saw blade is slipping to the back at the beginning of the cut	The saw blade is not sharp enough or is unsuitable for the type of material to be cut, or the surface of the wheel is defective

## 10 Circuit diagrams



**Attention!** The electrical diagrams supplied are only for the use of qualified electricians or the manufacturer's authorized technical personnel. These diagrams do not authorize you in any way to change the electrical parts or logic functioning.

## 10.1 Circuit diagram 1x 230 V

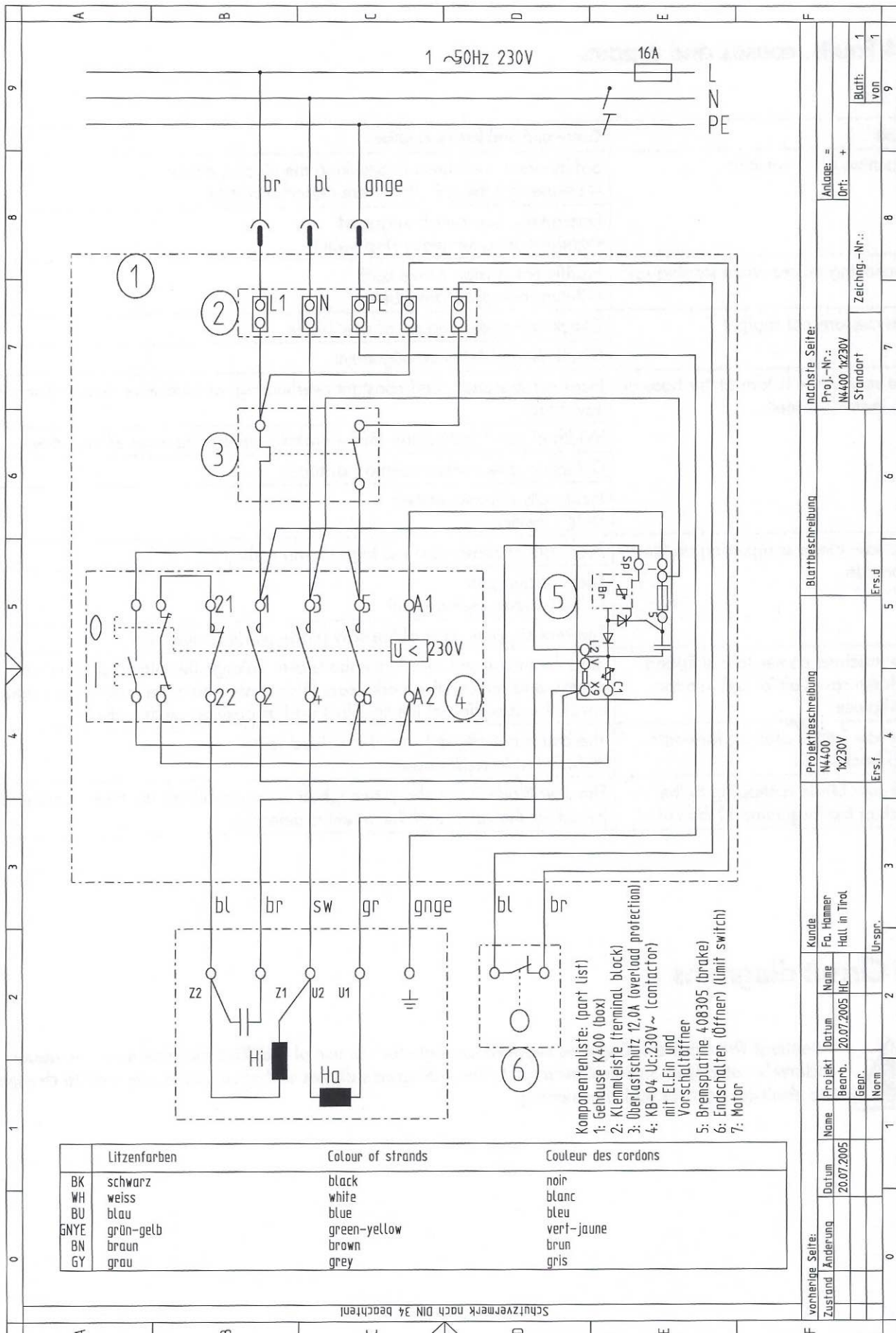

## 10.2 Circuit diagram 3x 400 V

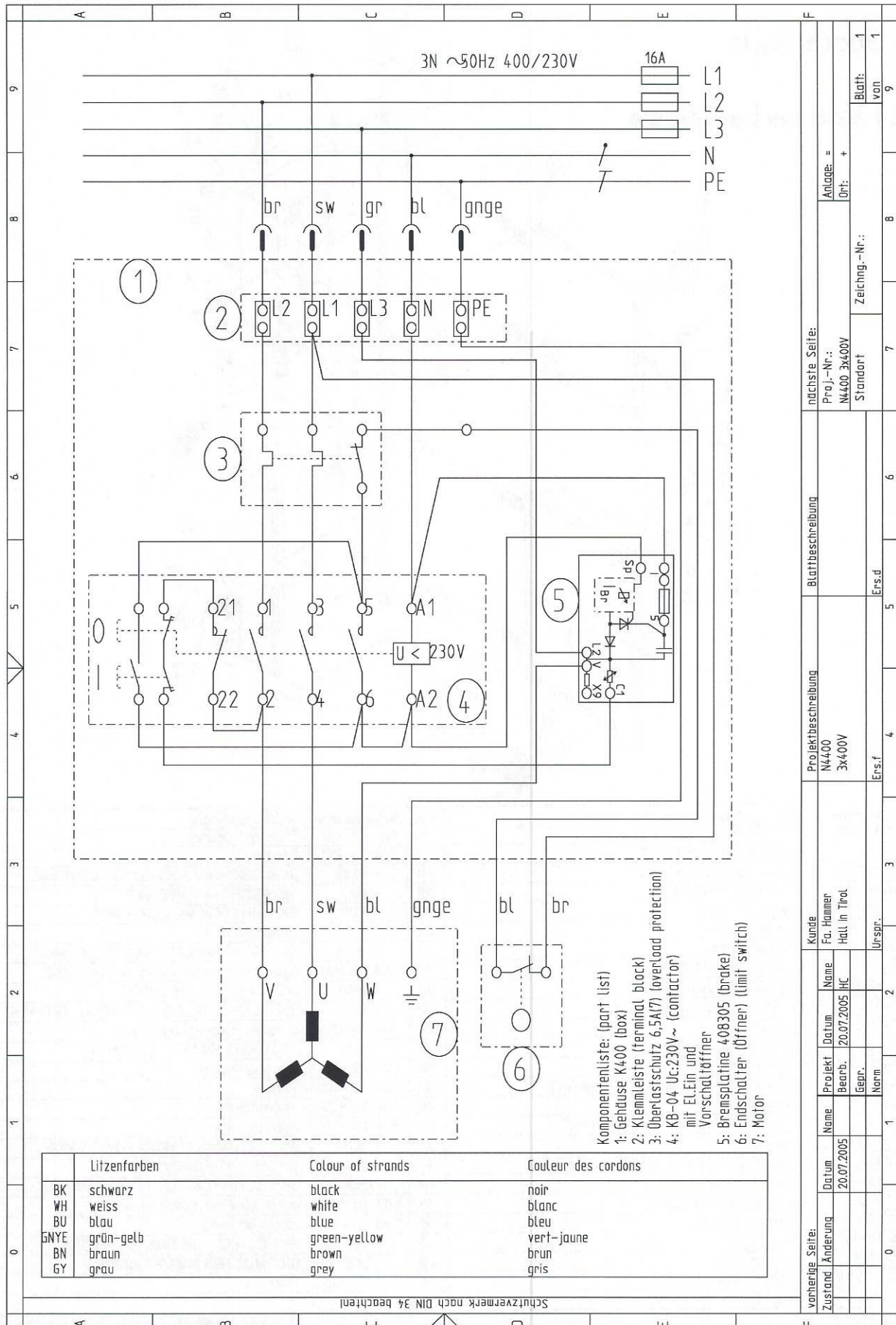

vorherige Seite:		Kunde		nächste Seite:	
Zustand	Änderung	Datum	Name	Projekt	Projekt-Nr.:
		20.07.2005	Fo. Hammer	N4400	N4400 3x400V
			Hall in Trol.	Bearb.	Standort
				Gepr.	Zeichung-Nr.:
				Norm	Blatt:
					von
					1
					9
					1

## 11 Spare parts

### 11.1 Machine base-frame

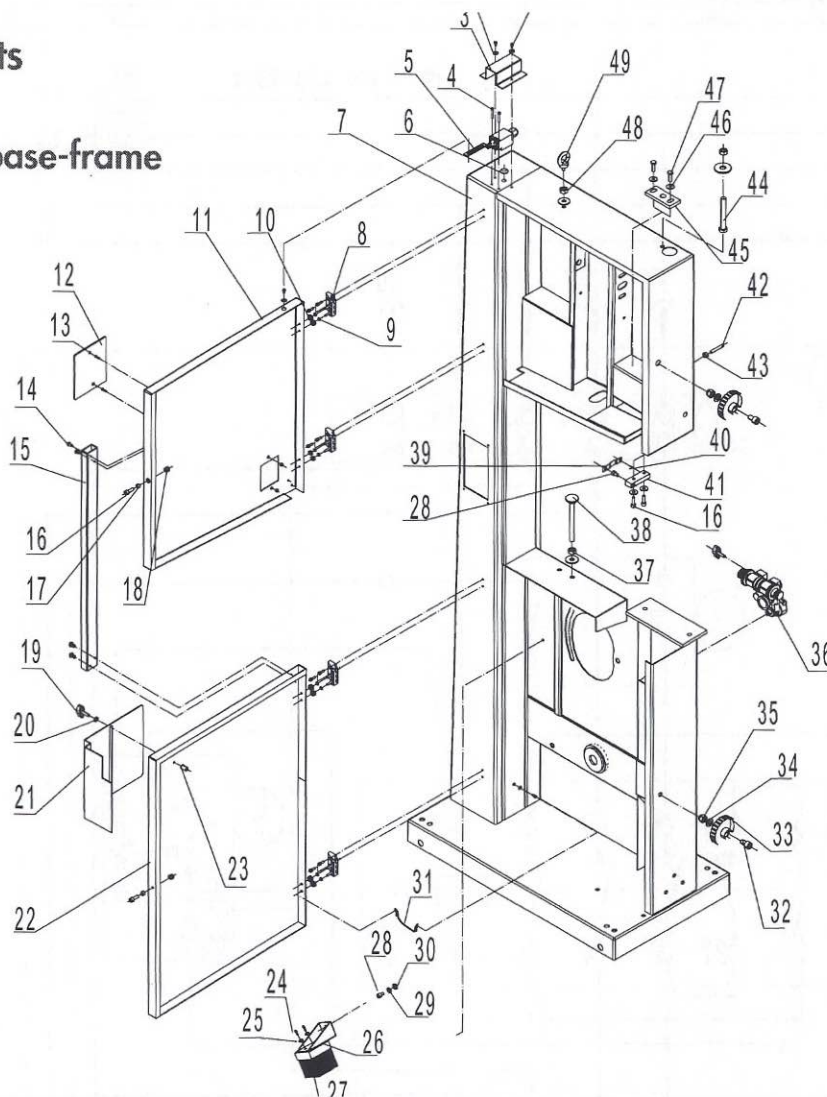

Pos.	Teilenummer	Teilebezeichnung	Pos.	Teilenummer	Teilebezeichnung
1	504-15-469	INBUSSCHRAUBE M412	26	504-15-482	Bürstenausleger
2	406AA	SCHEIBE M4 VERZINKT	27	504-15-481	Bürste
3	504-15-534	Schalterschutzabdeckung	28	423BB	INBUSSCHRAUBE M6X10 SCHWARZ
4	504-15-470	SCHRAUBE M4X40	29	406C	SCHEIBE M4 VERZINKT
5	504-15-525	Sicherheitsschalter	30	401D	SKT MUTTER M6 VERZINKT
6	504-15-483	Einspann Mutter	31		Erdungskabel
7	504-15-475	Bandsägerahmen	32	418EA	SKT SCHRAUBE M10X20 SCHWARZ
8	504-15-457	Türscharnier N4400/FB	33	504-15-458	Exzenterhandrad Türschließer N4400
9	406AA	SCHEIBE M4 VERZINKT	34	406EA	SCHEIBE M10 VERZINKT
10	401C	SKT MUTTER M4 VERZINKT	35	440C	SICHERHEITSECHSKANTMUTTER M10
11	504-15-543	obere Türe	36	504-15-503	unteres Führungsaggregat
12	504-15-487	durchsichtige Scheibe	37	401F	SKT MUTTER M10 VERZINKT
13	504-15-514	Flachkopfschraube	38	504-15-538	Tischhalterung
14	423BB	INBUSSCHRAUBE M6X10 SCHWARZ	39	504-15-478	Winkel
15	504-15-489	Verbindungsstück	40	504-15-523	Andruckrolle
16	418CJ	SKT SCHRAUBE M6X20 SCHWARZ	41	504-15-530	Sprungplatte
17	504-15-541	Schlauch	42	418CP	SKT SCHRAUBE M6X40 SCHWARZ
18	440A	SICHERHEITSECHSKANTMUTTER M6	43	401D	SKT MUTTER M6 VERZINKT
19	504-15-465	Flügelgriff M6x20	44	417DC	SKT SCHRAUBE M10X70 SCHWARZ
20	404D	SCHEIBE M8 VERZINKT	45	504-15-520	geführter Anschlusswinkel
21	504-15-497	Schutzabdeckung	46	504-15-476	große Scheibe
22	504-15-502	untere Tür	47	418CI	SKT SCHRAUBE M6X16 VERZINKT
23	504-15-522	Gewindemutter	48	401E	SKT MUTTER M8 VERZINKT
24	504-15-472	Blechschaube st 4.8x16	49	504-15-493	Flugring
25	404I	SCHEIBE M5 VERZINKT			

N4400-E01\_01

Stand 09/2008

Maschinenständer

gültig ab  
10/2007



Eigentum der Firma Felder KG. Es darf ohne Erlaubnis weder veräußert, kopiert noch 3. Personen mitgeteilt werden.



## 11.2 Machine table

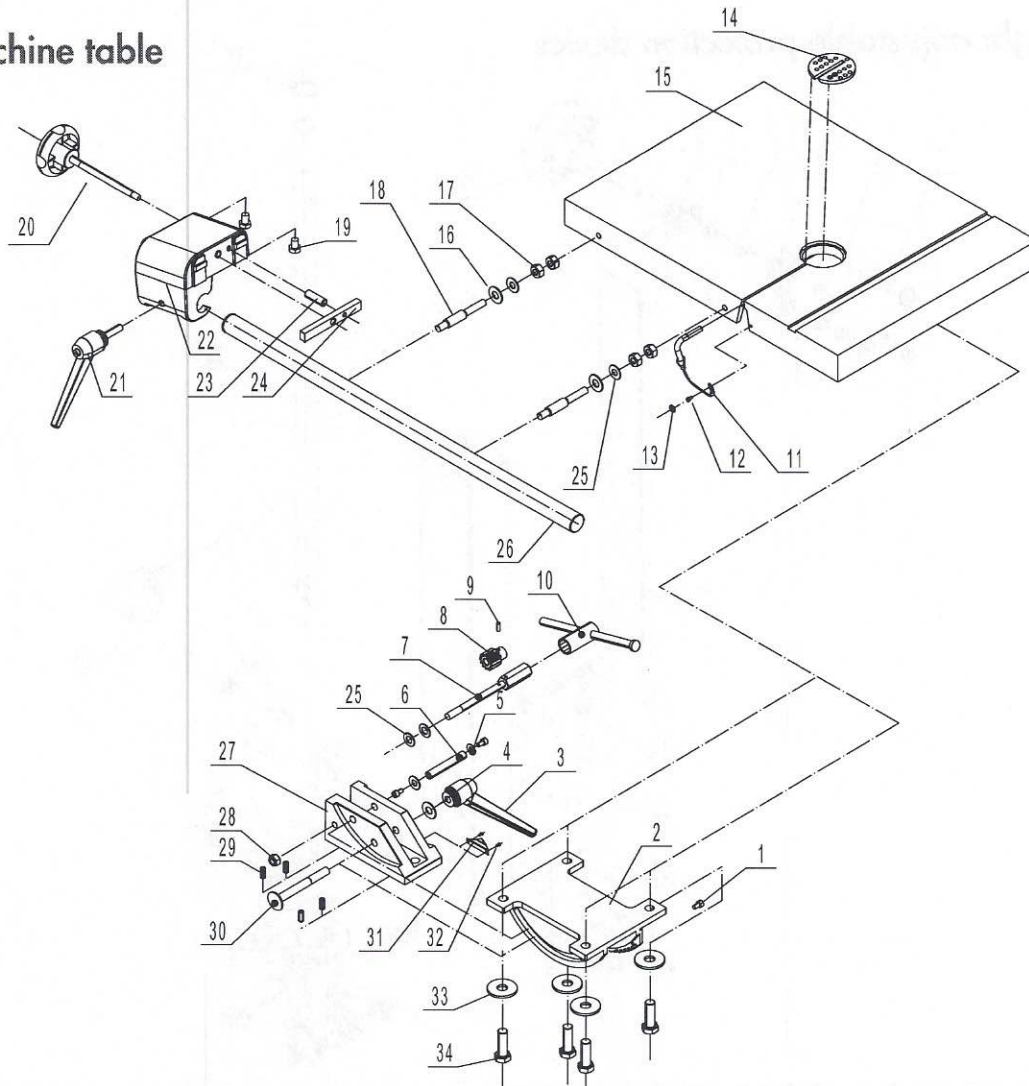

Pos.	Teilenummer	Teilebezeichnung	Pos.	Teilenummer	Teilebezeichnung
1	423BB	INBUSSCHRAUBE M6X10 SCHWARZ	26	504-15-498	Führungsschiene
2	504-15-539	Drehzapfenausleger	27	504-15-540	Drehzapfenausleger
3	504-15-464	Klemmhebel Euromodel,M12	28	440C	SICHERHEITSSSECHSKANTMUTTER M10
4	404F	SCHEIBE M12 VERZINKT	29	504-15-501	Abdrückschraube
5	406C	SCHEIBE M4 VERZINKT	30	504-15-484	Schlossschraube
6	504-15-499	Führungsachse	31	504-15-474	Winkelanzeige
7	504-15-496	Zahnradwelle	32	504-15-521	Gewinde
8	504-15-494	Zahnrad	33	402C	SKT MUTTER M12 VERZINKT FLACH
9	504-15-515	Bolzen	34	504-15-468	SKT SCHRAUBE M12X35
10	504-15-527	Schraubenschlüssel			
11	504-15-532	Stützseil			
12	504-15-469	INBUSSCHRAUBE M412			
13	402IA	SKT MUTTER M4 VERZINKT FLACH			
14	504-15-537	Tischeinsatz			
15	504-15-535	Tisch			
16	406EA	SCHEIBE M10 VERZINKT			
17	401F	SKT MUTTER M10 VERZINKT			
18	504-15-491	Anschlagsbolzen			
19	504-15-513	Kunststoffschraube			
20	504-15-467	Rändelschraube D40 M8x120			
21	504-15-466	Klemmhebel Euromodel, M10x20 Messing			
22	504-15-490	Anschlaggehäuse			
23	504-15-516	Bolzen			
24	504-15-479	Winkel			
25	406EA	SCHEIBE M10 VERZINKT			

## 11.3 Height adjustable protection device

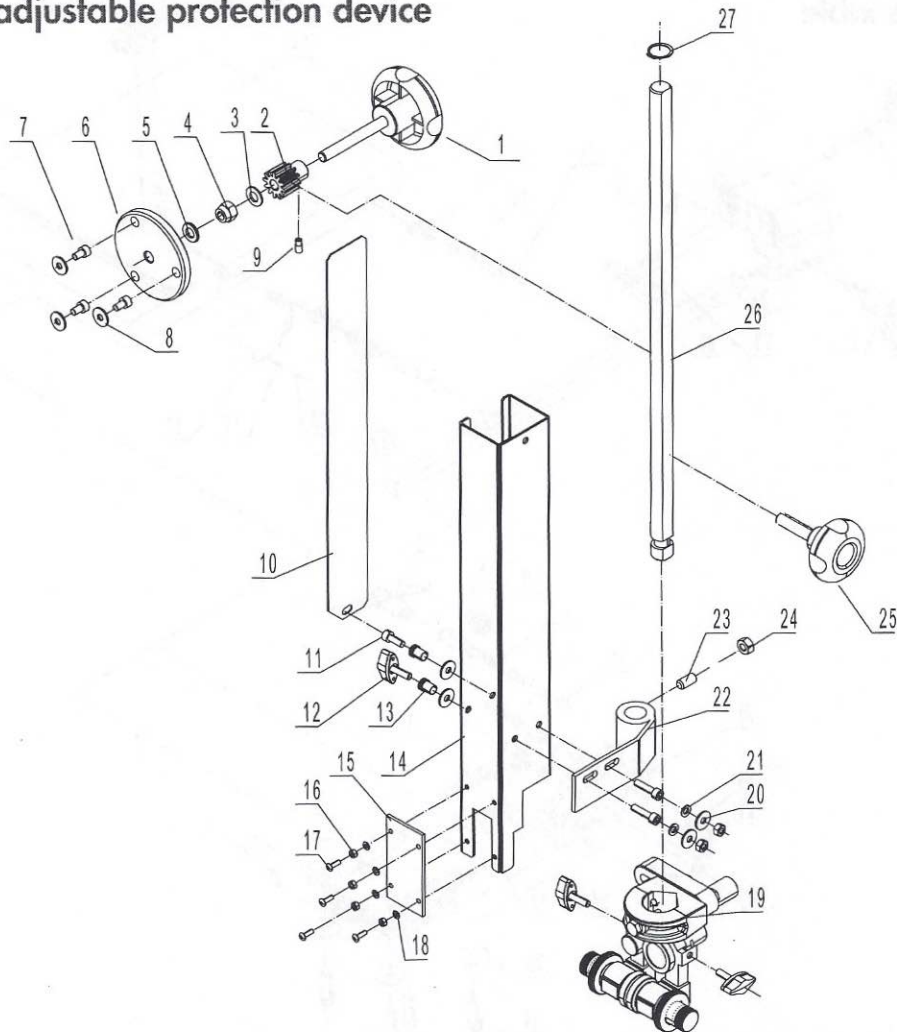

Pos.	Teilenummer	Teilebezeichnung	Pos.	Teilenummer	Teilebezeichnung
1	504-15-462	Rändelschraube D80 M10x60	26	504-15-500	geführter Anschlusswinkel
2	504-15-495	Zahnrad	27	504-15-485	Sicherungsring
3	406EA	SCHEIBE M10 VERZINKT			
4	440C	SICHERHEITSSSECHSKANTMUTTER M10			
5	407EA	FEDERRING M10 VERZINKT			
6	504-15-480	Winkel			
7	418CJ	SKT SCHRAUBE M6X20 SCHWARZ			
8	406C	SCHEIBE M4 VERZINKT			
9	423BB	INBUSSCHRAUBE M6X10 SCHWARZ			
10	504-15-531	Sprungplatte			
11	418CI	SKT SCHRAUBE M6X16 VERZINKT			
12	504-15-465	Flügelgriff M6x20			
13	504-15-522	Gewindemutter			
14	504-15-519	Schutzabdeckung			
15	504-15-488	durchsichtige Scheibe			
16	504-15-514	Flachkopfschraube			
17	401C	SKT MUTTER M4 VERZINKT			
18	406AA	SCHEIBE M4 VERZINKT			
19	504-15-542	oberes Klingenführungsaggregat			
20	406C	SCHEIBE M4 VERZINKT			
21	406C	SCHEIBE M4 VERZINKT			
22	504-15-492	fixer Anschlag			
23	418DC	SKT SCHRAUBE M8X20 SCHWARZ			
24	401E	SKT MUTTER M8 VERZINKT			
25	504-15-460	Rändelschraube D60 M12x45			

N4400-E03\_01  
Stand 09/2008

Höhenverstellbare Schutzeinrichtung

gültig ab  
10/2007



Eigentum der Firma Felder KG. Es darf ohne Erlaubnis weder veräußert, kopiert noch 3. Personen mitgeteilt werden.

Spare parts

## 11.4 Upper wheel

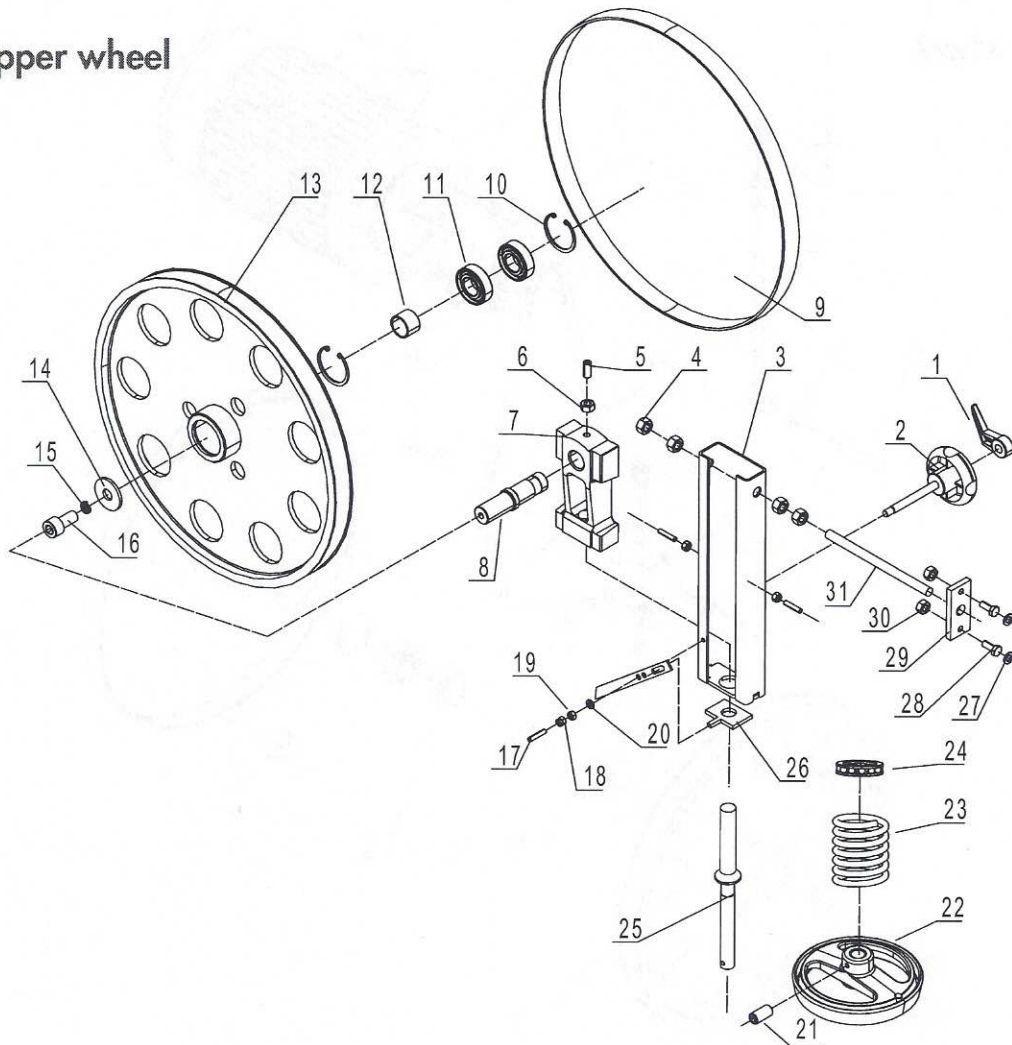

Pos.	Teilenummer	Teilebezeichnung	Pos.	Teilenummer	Teilebezeichnung
1	504-15-463	Klemmgriff M12	26	504-15-477	Block
2	504-15-461	Rändelschraube D80 M12x60	27	404D	SCHEIBE M8 VERZINKT
3	504-15-549	oberer Antriebsachsenausleger	28	418DQ	SKT SCHRAUBE M8X16 SCHWARZ
4	401HA	SKT MUTTER M14 VERZINKT	29	504-15-526	Auslegerachse
5	418EC	SKT SCHRAUBE M10X30 SCHWARZ	30	401E	SKT MUTTER M8 VERZINKT
6	401F	SKT MUTTER M10 VERZINKT	31	504-15-544	obere Achse
7	504-15-548	oberes Antriebsachsenscharnier			
8	504-15-547	obere Antriebsachse			
9	504-15-456	Sägebandauflage N4400 lt. Zg.503-007-028			
10	504-15-486	Sicherungsring			
11	432G	RILLENKUGELLAGER 6205 ZZ			
12	504-15-528	Distanzscheibe			
13	504-15-545	oberes Antriebsrad			
14	406EA	SCHEIBE M10 VERZINKT			
15	407EA	FEDERRING M10 VERZINKT			
16	418EA	SKT SCHRAUBE M10X20 SCHWARZ			
17	418CP	SKT SCHRAUBE M6X40 SCHWARZ			
18	440A	SICHERHEITSECHSESKANTMUTTER M6			
19	401D	SKT MUTTER M6 VERZINKT			
20	406C	SCHEIBE M4 VERZINKT			
21	418CI	SKT SCHRAUBE M6X16			
22	504-15-459	2-Speichen Handrad D-160			
23	504-15-529	Felder			
24	504-15-512	Nadellager			
25	504-15-473	Justierstange			

N4400-E04\_01  
Stand 09/2008

### Oberes Laufrad

gültig ab  
10/2007



Eigentum der Firma Felder KG. Es darf ohne Erlaubnis weder veräußert, kopiert noch 3. Personen mitgeteilt werden.

## 11.5 Lower wheel

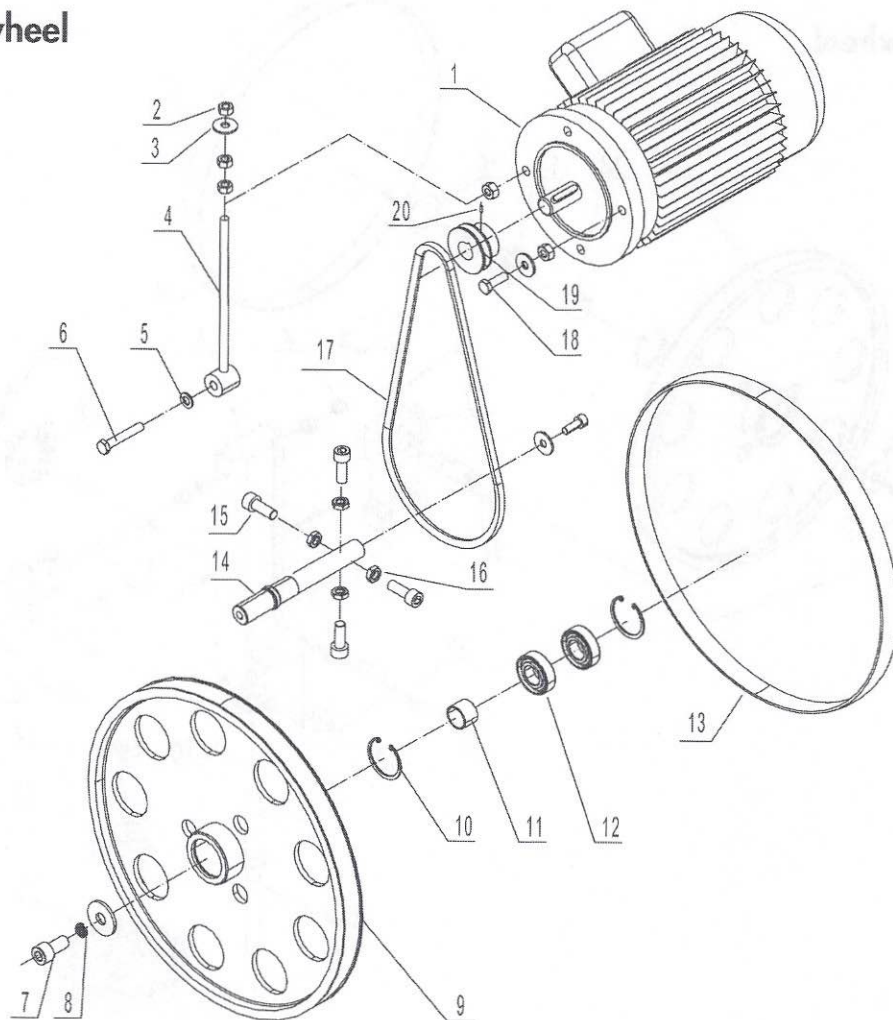

Pos.	Teilenummer	Teilebezeichnung	Pos.	Teilenummer	Teilebezeichnung
1	504-15-509	Motor 3x400V, 50Hz			
1	504-15-507	Motor 1x230V, 50Hz			
1	504-15-508	Motor 1x230V, 60Hz			
2	401F	SKT MUTTER M10 VERZINKT			
3	406EA	SCHEIBE M10 VERZINKT			
4	504-15-510	Motorhebel			
5	406EA	SCHEIBE M10 VERZINKT			
6	418EJ	SKT SCHRAUBE M10X60 SCHWARZ			
7	418EA	SKT SCHRAUBE M10X20 SCHWARZ			
8	407EA	FEDERRING M10 VERZINKT			
9	504-15-504	unteres Antriebsrad			
10	504-15-486	Sicherungsring			
11	504-15-528	Distanzscheibe			
12	432G	RILLENKUGELLAGER 6205 ZZ			
13	504-15-456	Sägebandauflage N4400 lt. Zg.503-007-028			
14	504-15-506	untere Antriebsachse			
15	421FB	INBUSSCHRAUBE M12X40 SCHWARZ			
16	401G	SKT MUTTER M12 VERZINKT			
17	500-12-008	Keilriemen SPZ 1000 für Bandsäge N4400			
18	418EC	SKT SCHRAUBE M10X30 SCHWARZ			
19	504-15-511	Motorriemenscheibe			
20	418CI	SKT SCHRAUBE M6X16			

N4400-E05\_01  
Stand 11/2011

Unteres Laufrad

gültig ab  
10/2007



Eigentum der Firma Felder KG. Es darf ohne Erlaubnis weder veräußert, kopiert noch 3. Personen mitgeteilt werden.

Spare parts

## 11.6 Safety equipment

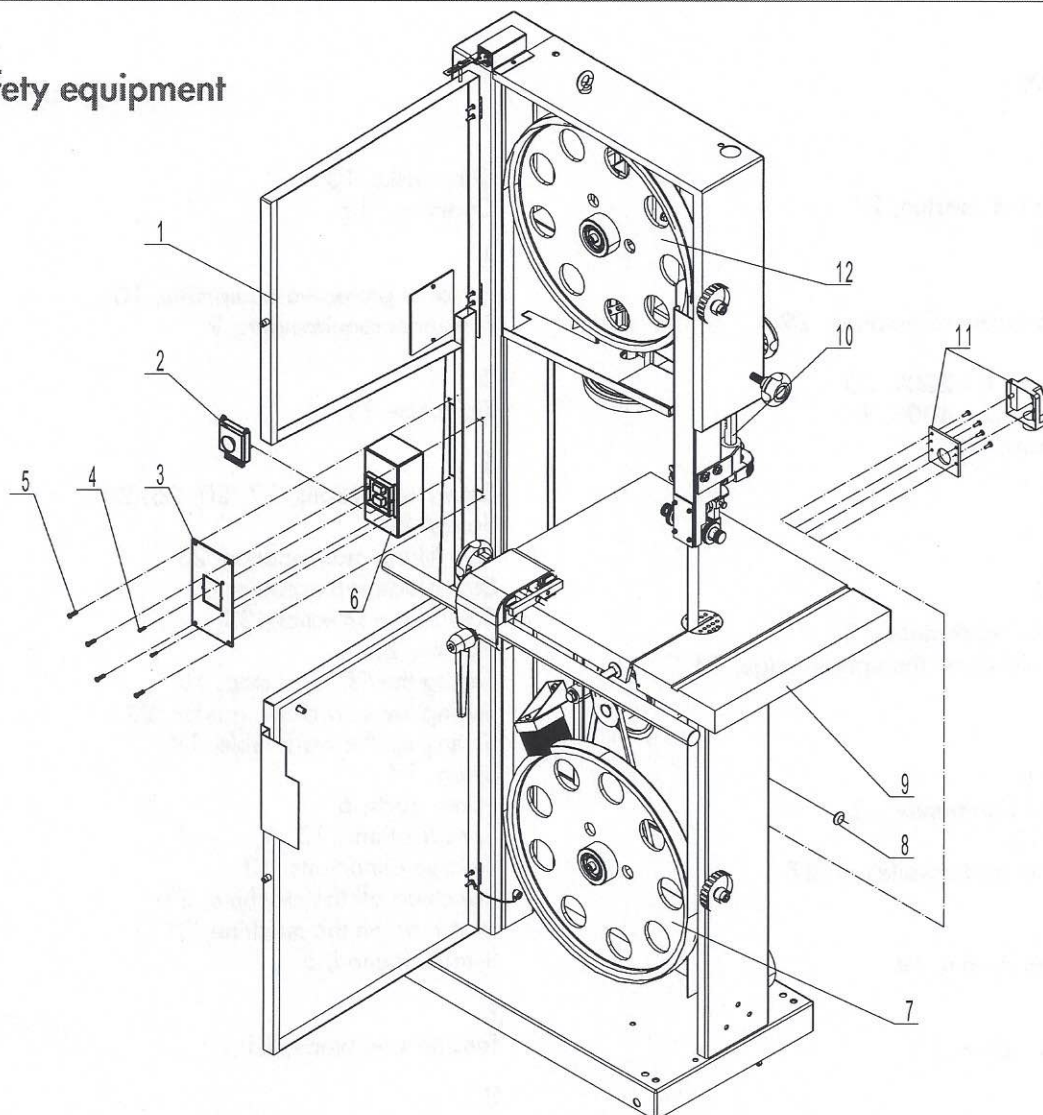

Pos.	Teilenummer	Teilebezeichnung	Pos.	Teilenummer	Teilebezeichnung
1	ANFRAGE	Maschinenständer			
2	ANFRAGE	Deckel E-Schalter			
3	504-15-533	Schalterabdeckplatte			
4	504-15-471	Blechschraube			
5	418AC	SKT SCHRAUBE M4X16 VERZINKT			
6	504-15-454	Elektroschaltgerät f.N4400 3x400,50Hz			
6	504-15-455	Elektroschaltgerät f.N4400 1x230,50Hz			
7	504-15-505	unteres Antriebsaggregat			
8	504-15-524	Gummimanschette(schlauch)			
9	504-15-536	Tischaggregat			
10	ANFRAGE	Blattschutz (Baugruppe)			
11	504-15-518	Anschlusstecker 3x400V			
12	504-15-546	oberes Antriebsaggregat			
15	504-15-509	Motor 3x400V, 50Hz			
16	504-15-517	Anschlusstecker 1x230V			
19	504-15-517	Anschlusstecker 1x230V			

N4400-E06\_01  
Stand 09/2008

### Schutzeinrichtungen

gültig ab  
10/2007



Eigentum der Firma Felder KG. Es darf  
ohne Erlaubnis weder veräußert, kopiert  
noch 3. Personen mitgeteilt werden.

## 12 Index

### A

Adjusting the belt tension, 27  
Assembly, 15

### C

Cause and problem elimination, 29  
Changes, 8  
Circuit diagram 1 x 230V, 30  
Circuit diagram 3 x 400V, 31  
Circuit diagrams, 29  
Circular cuts, 25  
Cleaning, 26  
Conversions, 8  
Copyright, 6  
Cross cut, 25  
Cutting circular work-pieces, 24  
Cutting workpieces on the upright edge, 24

### D

Dangers, 10  
Data plate, 16  
Declaration of Conformity, 11  
Dimensions, 12  
Direction of cut and parallelism, 27  
Disposal, 7  
Drive belts, 27  
Dust extraction system, 14

### E

Electrical connection, 12

### F

Faults, 29

### G

General, 5

### I

Installation, 17

### L

Liability, 6  
Longitudinal cut along a line, 23  
Longitudinal cut of narrow or thin work-pieces, 24  
Lower blade guide, 22  
Lubrication, 26

### M

Mitre cuts 25

### N

Noise emission, 12

### O

Operation, 20

Other risks, 10

Overview, 15

### P

Personal protective equipment, 10  
Personnel requirements, 9

### R

Rip fence, 19

### S

Safety instructions, 17, 20, 26, 28  
Safety, 8  
Saw blade maintenance, 23  
Saw blade replacement, 21  
Saw blade selection, 23  
Service, 26  
Setting the 90° end stop, 19  
Setting the saw blade guides, 22  
Setting up the work table, 18  
Setup, 17  
Spare parts, 6  
Specifications, 12  
Storage conditions, 13  
Switching off the machine, 21  
Switching on the machine, 21  
Symbol legend, 5

### T

Tension saw blade, 21

### U

Upper blade guide, 22

### W

Warranty notice, 6  
Warranty, 6  
Weight, 12  
What to do after rectifying the fault, 28  
What to do if a fault develops, 28  
Work safety, 9  
Working techniques, 23

**ORDER-FAX**  
**+43 5223 45 0 99**



Tel. +43 5223 45090



E-mail: [info@hammer.at](mailto:info@hammer.at)

Order No.	Article Description	Pcs.



**YES,** send me the new **HAMMER-catalog.**

First Name	Name/Company Name
Street + House-No.	Important: For company orders - please provide the VAT registration number!
Phone No. (Area Code)	Post Code/City
Mobile No. (Code)	Fax No. (Area Code)
	Availability (time)

Yes, please send me your Newsletter.

Email Address

Send to my address, subject to your delivery and payment conditions:

Date:  Signature:

**Hammer**  
**MAIL ORDER CARD**

Please stamp

**Hammer-Info-Zentrum**

**KR-FELDER-STR. 1**

**A-6060 HALL in Tirol  
Austria**

**HAMMER-Info-Zentrum**  
Tel.: (A) 0 52 23 / 45 0 90  
Fax: (A) 0 52 23 / 45 0 99  
Email: [info@hammer.at](mailto:info@hammer.at)  
<http://www.hammer.at>

**Business hours:**  
Mo. - Fr.: 09<sup>00</sup> - 12<sup>00</sup>  
          13<sup>00</sup> - 17<sup>00</sup>  
Sa.: 09<sup>00</sup> - 11<sup>30</sup>

# Hammer

KR-Felder-Str. 1  
A-6060 Hall in Tirol  
Tel.: +43 (0) 52 23 / 45 0 90  
Fax: +43 (0) 52 23 / 45 0 99  
Email: [info@hammer.at](mailto:info@hammer.at)  
Internet: [www.hammer.at](http://www.hammer.at)