

OPERATING MANUAL

ELLIOTT

UNIVERSAL
DIVIDING
HEADS

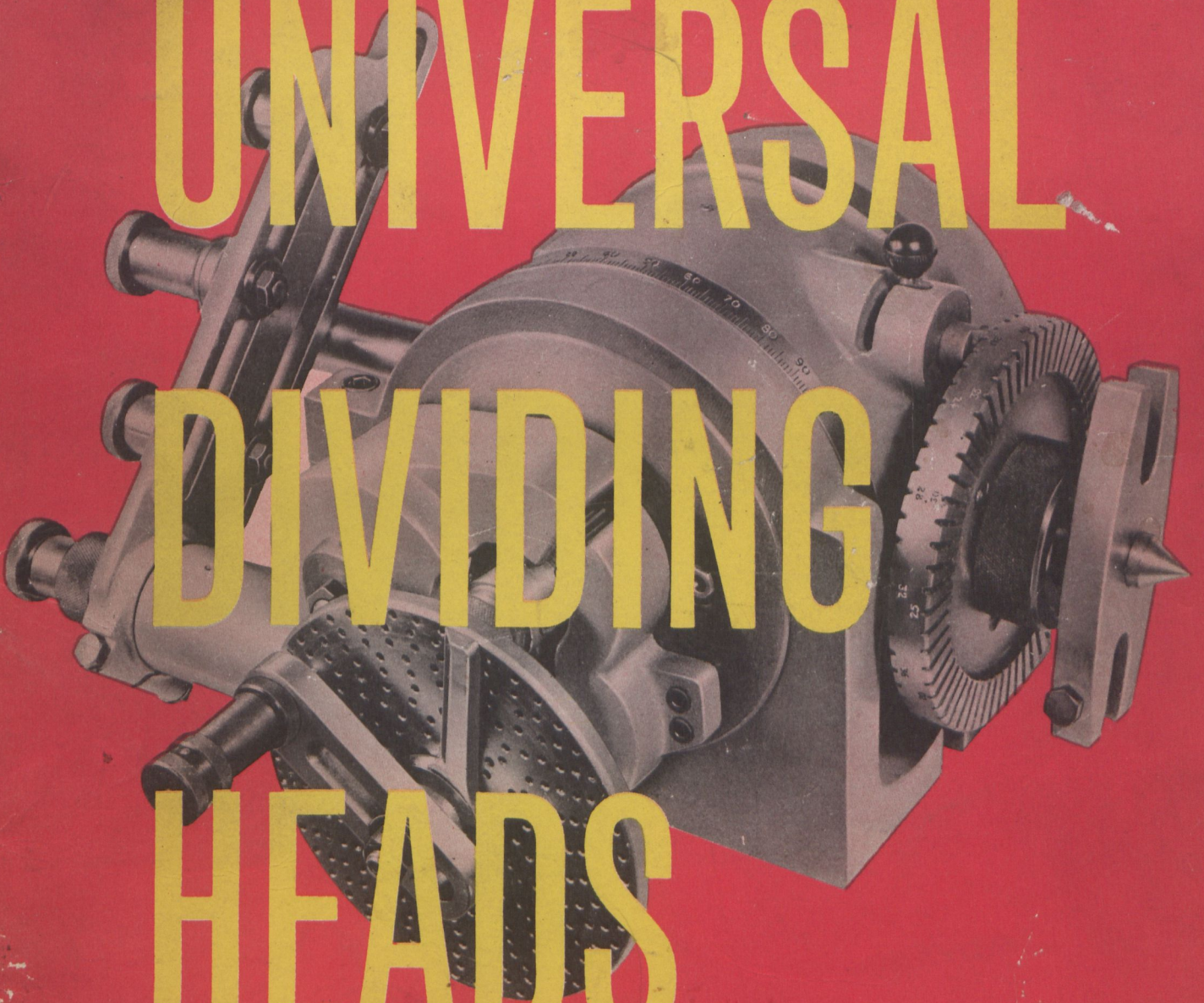

ELLIOTT 70 SERIES
UNIVERSAL MILLING MACHINE
MODEL 313

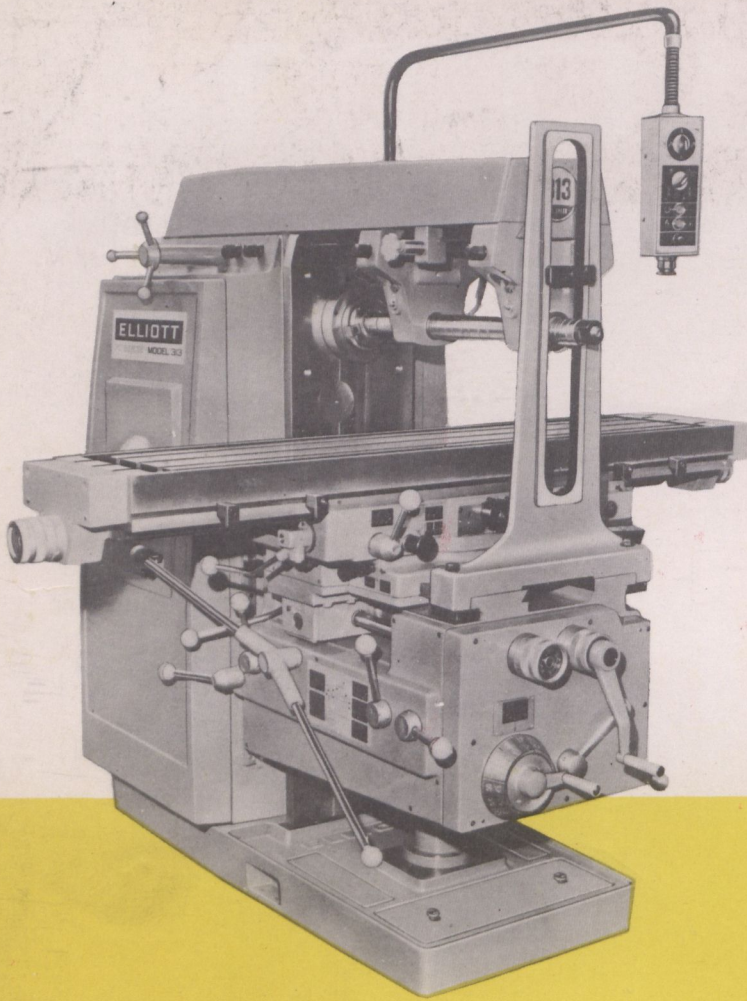

ELLIOTT MILLING MACHINES

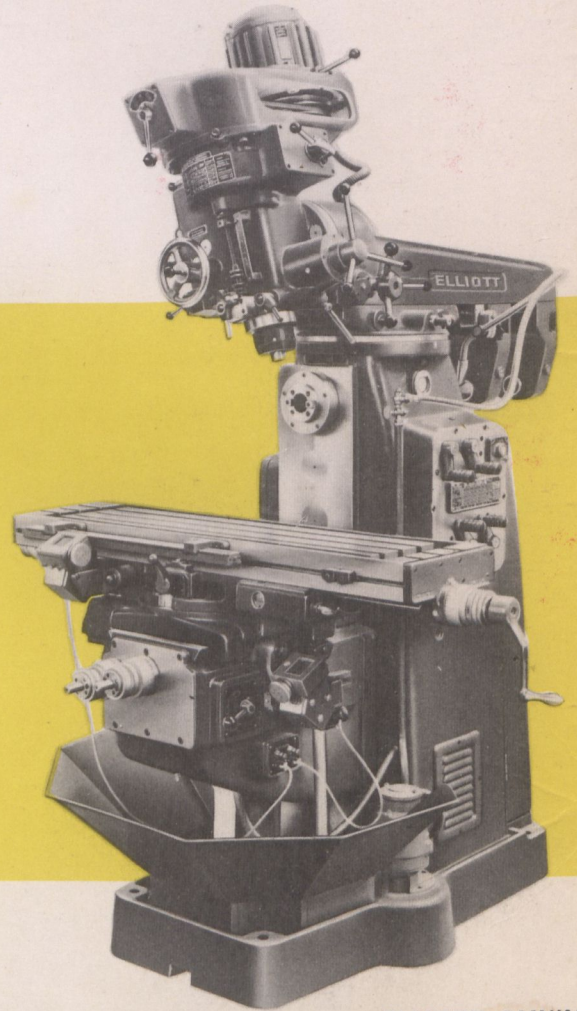

ELLIOTT OMNIMIL
MODEL 02

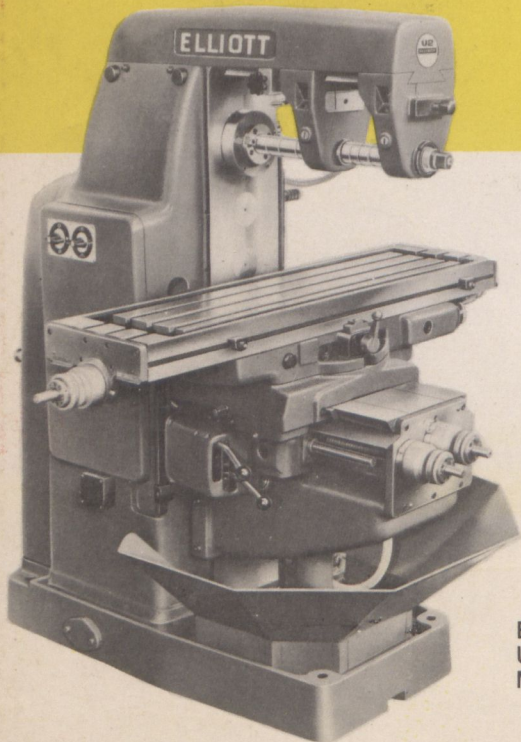

ELLIOTT
UNIVERSAL MILLING MACHINE
MODEL U2

LEAFLETS GIVING FULL DETAILS OF OUR RANGE OF 29 MODELS OF MILLING
MACHINES ARE AVAILABLE ON REQUEST

ELLIOTT

Parkside Steel 020 8801 7199
Units 7-8 Mowlem Trading Estate
Leeside Road
N.17 0QJ.

UNIVERSAL

DIVIDING

HEADS



ELLIOTT

Contents

	Page
INTRODUCTION	3
SIMPLE AND INDIRECT INDEXING CHART	4
DIFFERENTIAL INDEXING	5- 7
TABLE OF LEADS	8-13
METHOD OF MOUNTING DIVIDING HEAD ON MACHINE TABLE	14
DIRECT INDEXING	15
INDIRECT INDEXING	16
INDEXING ANGLES	16
DIFFERENTIAL INDEXING	17
BLOCK INDEXING	18
LOW LEAD ATTACHMENT	19
CUTTING HELICES	20
CALCULATION OF CHANGE GEARS	21
GEAR CUTTING	22
STRAIGHT TOOTH SPUR GEARS	22
SINGLE HELICAL GEARS	23
NON-STANDARD LEADS	24
WORM GEARS	26
CAM MILLING	28
MILLING CLUTCH TEETH	30
ADJUSTMENTS AND MAINTENANCE	32
SPECIFICATION	34
7" SWING DIVIDING HEAD PARTS LIST	36
9", 10" & 12" SWING DIVIDING HEAD PARTS LIST	38
NOMOGRAPH TO GIVE ANGULAR SETTINGS FOR SPIRAL MILLING	iii

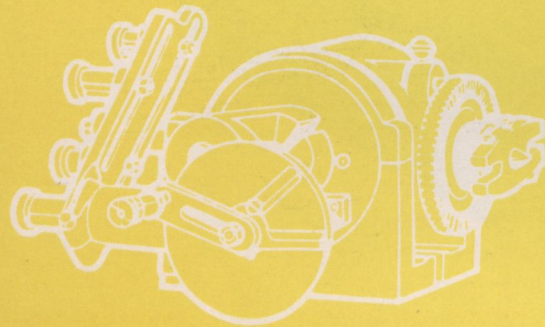

**PRECISION
UNIVERSAL
DIVIDING
HEADS**



ELLIOTT

7", 9", 10" AND 12" SWING PRECISION UNIVERSAL DIVIDING HEAD

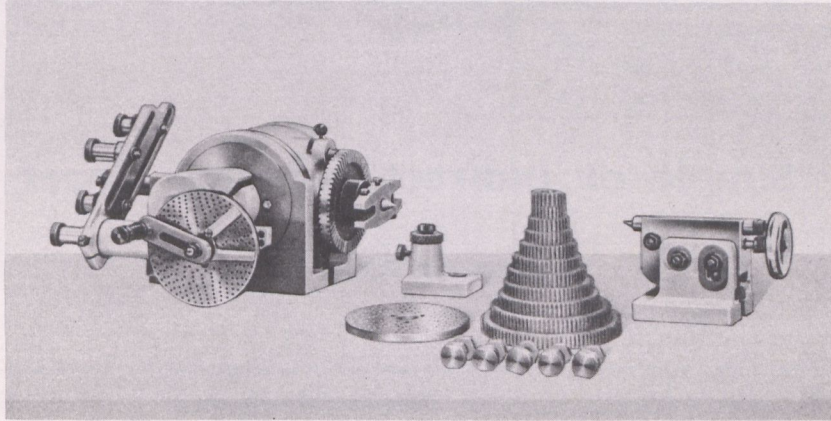

These Dividing Heads together with their standard sets of change gears and hole circle plates provide a complete range of divisions and leads as tabulated in the following pages. They are fully universal so that they can be used for generating cams as well as for helical milling, and any number of divisions capable of simple indexing can be achieved with the work spindle in any position from the horizontal to the vertical.

The master worm wheels are cut on special single purpose hobbing machines provided with a pitch correction mechanism and the threads of the worm are finished on a precision thread grinding machine. Modern machines and carefully maintained tooling are used to produce all the main components to a similar high standard of accuracy and the result is that total accumulated error including cyclical effects is held within 1 min. 30 secs. of arc.

Each unit is subjected to a vigorous final inspection procedure which includes testing for spacing error on an optical equipment capable of registering errors of 5 seconds of arc (0.00007" at 3" radius).

All parts which could with advantage be hardened and ground are made from alloy steels suitably heat treated whilst the main castings are high grade cast iron. The worm wheel is made of hard gear bronze.

ELLIOTT

7", 9", 10" AND 12" SWING

PRECISION UNIVERSAL DIVIDING HEAD

Simple or Indirect Indexing Chart

RATIO OF HEAD 1:40

Standard Plates—Index plate 1

Hole Circles—15, 18, 20, 23, 27, 31, 37, 41, 47

" " 2

" 16, 17, 19, 21, 29, 33, 39, 43, 49

No. of divisions	Hole Circle	complete turns	INDEX ARM Fraction of a turn.	No. of divisions	Hole Circle	complete turns	INDEX ARM Fraction of a turn.	No. of divisions	Hole Circle	complete turns	INDEX ARM Fraction of a turn.	No. of divisions	Hole Circle	Fraction of a turn.	INDEX ARM Fraction of a turn.	No. of divisions	Hole Circle	Fraction of a turn.	INDEX ARM Fraction of a turn.	
2	-	20	-	18	27	2	6/27	36	27	1	3/27	62	31	20/31	115	23	8/23	185	37	8/37
3	39	13	13/39	18	18	2	4/18	37	37	1	3/37	64	16	10/16	116	29	10/29	188	47	10/47
	27	13	9/27	19	19	2	2/19	38	19	1	1/19	65	39	24/39	120	39	13/39	190	19	4/19
4	-	10	-	20	-	2	-	39	39	1	1/39	66	33	20/33		27	9/27	195	39	8/39
5	-	8	-	21	21	1	19/21	40	-	1	-	68	17	10/17	124	31	10/31	196	49	10/49
6	39	6	26/39	22	33	1	27/33	41	41	-	40/41	70	49	28/49	128	16	5/16	200	20	4/20
	27	6	18/27	23	23	1	17/23	42	21	-	20/21	72	27	15/27	130	39	12/39	205	41	8/41
7	49	5	35/49	24	39	1	26/39	43	43	-	40/43	74	37	20/37	132	33	10/33	210	21	4/21
	21	5	15/21		27	1	18/27	44	33	-	30/33	75	15	8/15	135	27	8/27	215	43	8/43
8	-	5	-	25	20	1	12/20	45	27	-	24/27	76	19	10/19	136	17	5/17	216	27	5/27
9	27	4	12/27	26	39	1	21/39	46	23	-	20/23	78	39	20/39	140	49	14/49	220	33	6/33
	18	4	8/18	27	27	1	13/27	47	47	-	40/47	80	20	10/20	144	18	5/18	230	23	4/23
10	-	4	-	28	49	1	21/49	48	18	-	15/18	82	41	20/41	145	29	8/29	232	29	5/29
11	33	3	21/33		21	1	9/21	49	49	-	40/49	84	21	10/21	148	37	10/37	235	47	8/47
12	39	3	13/39	29	29	1	11/29	50	20	-	16/20	85	17	8/17	150	15	4/15	240	18	3/18
	27	3	9/27	30	39	1	13/39	52	39	-	30/39	86	43	20/43	152	19	5/19	245	49	8/49
13	39	3	3/39		27	1	9/27	54	27	-	20/27	88	33	15/33	155	31	8/31	248	31	5/31
14	49	2	42/49	31	31	1	9/31	55	33	-	24/33	90	27	12/27	156	39	10/39	260	39	6/39
	21	2	18/21	32	20	1	5/20	56	49	-	35/49	92	23	10/23	160	20	5/20	264	33	5/33
15	39	2	26/39	33	33	1	7/33	58	29	-	20/29	94	47	20/47	164	41	10/41	270	27	4/27
	27	2	18/27	34	17	1	3/17	60	39	-	26/39	95	19	8/19	165	33	8/33	280	49	7/49
16	20	2	10/20	35	49	1	7/49		27	-	18/27	98	49	20/49	168	21	5/21	290	29	4/29
17	17	2	6/17		21	1	3/21					100	20	8/20	170	17	4/17	296	37	5/37
												104	39	15/39	172	43	10/43	300	15	2/15
												105	21	8/21	180	27	6/27	360	18	2/18
												108	27	10/27		18	4/18		27	3/27
												110	33	12/33	184	23	5/23	400	20	2/20

CHANGE GEARS and MOVEMENTS for DIFFERENTIAL INDEXING

Ratio of Head I : 40

PITCH CIRCLES PROVIDED : 15, 16, 17, 18,
19, 20, 21, 23, 27, 29, 31, 33, 37, 39, 41, 43,
47, 49 holes.

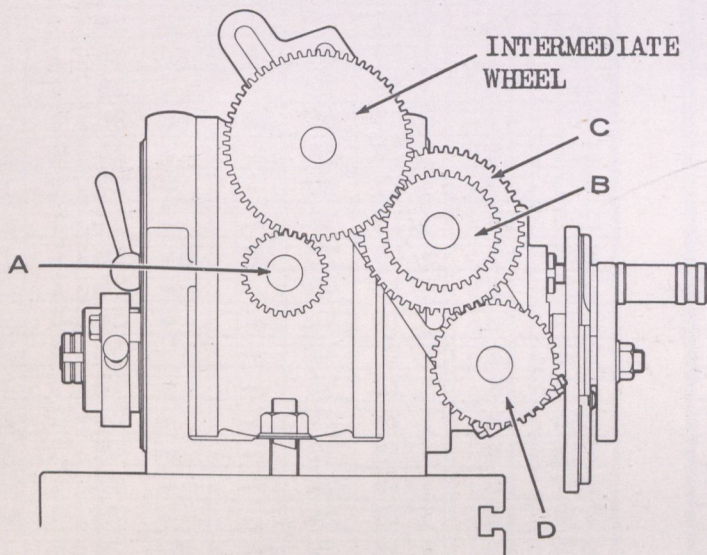

LEFT HANDED MODEL

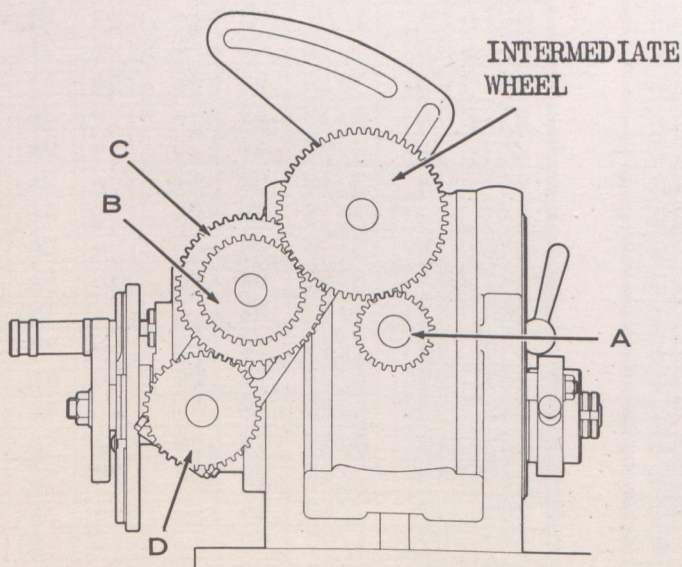

RIGHT HANDED MODEL

Dividing number	Pitch circle	Revolution of the Index Arm	Wheel on the spindle of the dividing head		Wheel on the compound sleeve		Wheel on the shaft of the dividing disc	Number of intermediate wheels	
			A	B	C	D		L.H. HEAD	R.H. HEAD
51	17	14/17	48	-	-	24	2	1	
53	49	35/49	72	24	40	56	-	1	
57	49	35/49	40	-	-	56	2	1	
59	33	22/33	32	-	-	48	1	2	
61	33	22/33	32	-	-	48	2	1	
63	33	22/33	48	-	-	24	2	1	
67	49	28/49	48	-	-	28	1	2	
69	20	12/20	56	-	-	40	2	1	
71	27	15/27	40	-	-	72	1	2	
73	49	28/49	48	-	-	28	2	1	
77	20	10/20	48	-	-	32	1	2	
79	20	10/20	24	-	-	48	1	2	
81	20	10/20	24	-	-	48	2	1	
83	20	10/20	48	-	-	32	2	1	
87	15	7/15	24	-	-	40	2	1	
89	27	12/27	32	-	-	72	1	2	
91	39	18/39	48	-	-	24	2	1	
93	27	12/27	32	-	-	24	2	1	
96	49	21/49	32	-	-	28	2	1	
97	20	8/20	48	-	-	40	1	2	
99	20	8/20	32	40	28	56	-	1	
101	20	8/20	48	40	24	72	1	-	
102	20	8/20	32	-	-	40	2	1	
103	20	8/20	48	-	-	40	2	1	
106	43	16/43	48	24	24	86	-	1	
107	20	8/20	64	32	56	40	1	-	
109	16	6/16	28	-	-	32	2	1	
111	39	13/39	72	-	-	24	1	2	
112	33	11/33	64	-	-	24	1	2	
113	39	13/39	56	-	-	24	1	2	
114	39	13/39	48	-	-	24	1	2	
117	33	11/33	24	-	-	24	1	2	
118	39	13/39	32	-	-	48	1	2	
119	39	13/39	24	-	-	72	1	2	
121	39	13/39	24	-	-	72	2	1	
122	39	13/39	32	-	-	48	2	1	
123	39	13/39	24	-	-	24	2	1	
125	39	13/39	40	-	-	24	2	1	
126	39	13/39	48	-	-	24	2	1	
127	39	13/39	56	-	-	24	2	1	
129	39	13/39	72	-	-	24	2	1	
131	20	6/20	28	-	-	40	1	2	
133	49	14/49	48	-	-	24	1	2	
134	49	14/49	48	-	-	28	1	2	
137	49	14/49	24	-	-	28	1	2	
138	49	14/49	32	-	-	56	1	2	
139	49	14/49	24	48	32	56	-	1	

CHANGE GEARS and MOVEMENTS for DIFFERENTIAL INDEXING—cont.

Dividing number	Pitch circle	Revolution of the Index Arm	Wheel on the spindle of the dividing head	Wheel on the compound sleeve	Wheel on the compound sleeve	Wheel on the shaft of the dividing disc	Number of Intermediate wheels	
			A	B	C	D	L.H. HEAD	R.H. HEAD
141	18	5/18	40	-	-	48	1	2
142	49	14/49	32	-	-	56	2	1
143	49	14/49	24	-	-	28	2	1
146	49	14/49	48	-	-	28	2	1
147	49	14/49	48	-	-	24	2	1
149	49	14/49	72	-	-	28	2	1
151	20	5/20	72	-	-	32	1	2
153	20	5/20	56	-	-	32	1	2
154	20	5/20	48	-	-	32	1	2
157	20	5/20	24	-	-	32	1	2
158	20	5/20	24	-	-	48	1	2
159	20	5/20	28	56	32	64	-	1
161	20	5/20	28	56	32	64	1	-
162	20	5/20	24	-	-	48	2	1
163	20	5/20	24	-	-	32	2	1
166	20	5/20	48	-	-	32	2	1
167	20	5/20	56	-	-	32	2	1
169	20	5/20	72	-	-	32	2	1
171	21	5/21	40	-	-	56	2	1
173	27	6/27	64	32	56	72	-	1
174	27	6/27	32	-	-	24	1	2
175	27	6/27	64	32	40	72	-	1
176	27	6/27	64	24	24	72	-	1
177	27	6/27	48	-	-	72	1	2
178	27	6/27	32	-	-	72	1	2
179	27	6/27	32	48	24	72	-	1
181	27	6/27	32	48	24	72	1	-
182	27	6/27	32	-	-	72	2	1
183	27	6/27	32	-	-	48	2	1
186	27	6/27	64	-	-	48	2	1
187	27	6/27	56	24	48	72	1	-
189	27	6/27	64	-	-	32	2	1
191	20	4/20	72	-	-	40	1	2
192	20	4/20	64	-	-	40	1	2
193	20	4/20	56	-	-	40	1	2
194	20	4/20	48	-	-	40	1	2
197	20	4/20	24	-	-	40	1	2
198	20	4/20	32	40	28	56	-	1
199	20	4/20	32	64	40	100	-	1
201	20	4/20	24	40	24	72	-	1
202	20	4/20	48	40	24	72	1	-
203	20	4/20	24	-	-	40	2	1
204	20	4/20	32	-	-	40	2	1
206	20	4/20	48	-	-	40	2	1
207	20	4/20	56	-	-	40	2	1
208	20	4/20	64	-	-	40	2	1
209	20	4/20	72	-	-	40	2	1
211	16	3/16	28	-	-	64	1	2

Dividing number	Pitch circle	Revolution of the Index Arm	Wheel on the spindle of the dividing head	Wheel on the compound sleeve	Wheel on the compound sleeve	Wheel on the shaft of the dividing disc	Number of Intermediate wheels	
			A	B	C	D	L.H. HEAD	R.H. HEAD
212	43	8/43	48	24	24	86	-	1
213	27	5/27	40	-	-	72	1	2
214	20	4/20	64	32	56	40	1	-
217	21	4/21	64	-	-	48	2	1
218	16	3/16	56	-	-	64	2	1
219	21	4/21	48	-	-	28	2	1
221	17	3/17	24	-	-	24	1	2
222	18	3/18	72	-	-	24	1	2
223	43	8/43	64	24	48	86	1	-
224	18	3/18	64	-	-	24	1	2
225	27	5/27	40	-	-	24	2	1
226	18	3/18	56	-	-	24	1	2
227	49	8/49	72	28	64	56	-	1
228	18	3/18	48	-	-	24	1	2
229	18	3/18	44	-	-	24	1	2
231	18	3/18	48	-	-	32	1	2
233	18	3/18	56	-	-	40	1	2
234	18	3/18	24	-	-	24	1	2
236	18	3/18	32	-	-	48	1	2
237	18	3/18	24	-	-	48	1	2
238	18	3/18	24	-	-	72	1	2
239	18	3/18	32	64	24	72	-	1
241	18	3/18	32	64	24	72	1	-
242	18	3/18	24	-	-	72	2	1
243	18	3/18	32	-	-	64	2	1
244	18	3/18	32	-	-	48	2	1
246	18	3/18	24	-	-	24	2	1
247	18	3/18	56	-	-	48	2	1
249	18	3/18	48	-	-	32	2	1
250	18	3/18	40	-	-	24	2	1
251	18	3/18	64	32	44	48	1	1
252	18	3/18	48	-	-	24	2	1
253	33	5/33	40	-	-	24	1	1
254	18	3/18	56	-	-	24	2	1
255	18	3/18	72	24	40	48	1	-
256	18	3/18	64	-	-	24	2	1
257	49	8/49	64	28	48	56	1	-
258	43	7/43	64	-	-	32	2	1
259	49	7/49	72	-	-	24	1	2
261	29	4/29	72	24	64	48	-	1
262	20	3/20	28	-	-	40	1	2
263	49	8/49	72	28	64	56	1	-
265	49	7/49	72	24	40	56	-	1
266	49	7/49	64	-	-	32	1	2
267	27	4/27	32	-	-	72	1	2
268	49	7/49	48	-	-	28	1	2
269	20	3/20	28	40	32	64	1	-
271	49	7/49	72	-	-	56	1	2

CHANGE GEARS and MOVEMENTS for DIFFERENTIAL INDEXING—cont.

Dividing number	Pitch circle	Revolution of the Index Arm	Wheel on the spindle of the dividing head	Wheel on the compound sleeve	Wheel on the compound sleeve	Wheel on the shaft of the dividing disc	Number of Intermediate wheels	Number of Intermediate wheels
			A	B	C	D	L.H. HEAD	R.H. HEAD
272	49	7/49	64	-	-	56	1	2
273	49	7/49	24	-	-	24	1	2
274	49	7/49	48	-	-	56	1	2
275	49	7/49	40	-	-	56	1	2
276	49	7/49	32	-	-	56	1	2
277	49	7/49	24	-	-	56	1	2
278	49	7/49	24	48	32	56	-	1
279	27	4/27	32	-	-	24	2	1
281	49	7/49	24	56	24	72	1	-
282	43	6/43	56	24	24	86	-	1
283	49	7/49	24	-	-	56	2	1
284	49	7/49	32	-	-	56	2	1
285	49	7/49	40	-	-	56	2	1
286	49	7/49	48	-	-	56	2	1
287	49	7/49	24	-	-	24	2	1
288	49	7/49	32	-	-	28	2	1
289	49	7/49	72	-	-	56	2	1
291	15	2/15	48	-	-	40	1	2
292	49	7/49	48	-	-	28	2	1
293	15	2/15	56	40	32	48	-	1
294	49	7/49	48	-	-	24	2	1
295	15	2/15	32	-	-	48	1	2
297	33	4/33	56	24	48	28	-	1
298	49	7/49	72	-	-	28	2	1
299	23	3/23	24	-	-	24	1	2
301	43	6/43	48	-	-	24	2	1
302	16	2/16	72	-	-	32	1	2
303	15	2/15	48	40	24	72	1	-
304	16	2/16	48	-	-	24	1	2
305	15	2/15	32	-	-	48	2	1
306	15	2/15	32	-	-	40	2	1
307	15	2/15	56	40	48	72	1	-
308	16	2/16	48	-	-	32	1	2
309	15	2/15	48	-	-	40	2	1
311	16	2/16	72	24	24	64	-	1
313	16	2/16	28	-	-	32	1	2
314	16	2/16	24	-	-	32	1	2
315	16	2/16	40	-	-	64	1	2
316	16	2/16	32	-	-	64	1	2
317	16	2/16	24	-	-	64	1	2
318	16	2/16	24	48	28	56	-	1
319	29	4/29	72	24	64	48	1	-
321	16	2/16	24	64	24	72	1	-
322	23	3/23	64	-	-	32	2	1
323	16	2/16	24	-	-	64	2	1
324	16	2/16	32	-	-	64	2	1
325	16	2/16	40	-	-	64	2	1
326	16	2/16	24	-	-	32	2	1

Dividing number	Pitch circle	Revolution of the Index Arm	Wheel on the spindle of the dividing head	Wheel on the compound sleeve	Wheel on the compound sleeve	Wheel on the shaft of the dividing disc	Number of Intermediate wheels	Number of Intermediate wheels
			A	B	C	D	L.H. HEAD	R.H. HEAD
327	16	2/16	28	-	-	32	2	1
329	16	2/16	72	24	24	64	1	-
331	16	2/16	48	24	44	64	1	-
332	16	2/16	48	-	-	32	2	1
333	27	3/27	72	-	-	24	1	2
334	16	2/16	56	-	-	32	2	1
335	33	4/33	40	44	48	72	1	-
336	16	2/16	64	-	-	32	2	1
337	43	5/43	56	32	40	86	-	1
338	16	2/16	72	-	-	32	2	1
339	27	3/27	56	-	-	24	1	2
341	43	5/43	40	32	24	86	-	1
342	27	3/27	64	-	-	32	1	2
343	15	2/15	86	24	64	40	1	-
345	27	3/27	40	-	-	24	1	2
346	27	3/27	64	32	56	72	-	1
347	43	5/43	40	32	24	86	1	-
348	27	3/27	32	-	-	24	1	2
349	27	3/27	48	24	44	72	-	1
350	27	3/27	64	32	40	72	-	1
351	27	3/27	24	-	-	24	1	2
352	27	3/27	64	24	24	72	-	1
353	27	3/27	56	-	-	72	1	2
354	27	3/27	48	-	-	72	1	2
355	27	3/27	40	-	-	72	1	2
356	27	3/27	32	-	-	72	1	2
357	27	3/27	24	-	-	72	1	2
358	27	3/27	24	48	32	72	-	1
359	43	5/43	100	32	48	86	1	-
361	19	2/19	64	-	-	32	1	2
362	27	3/27	32	56	28	72	1	-
363	27	3/27	24	-	-	72	2	1
364	27	3/27	32	-	-	72	2	1
365	20	2/20	56	24	48	32	-	1
366	27	3/27	32	-	-	48	2	1
367	27	3/27	56	-	-	72	2	1
368	27	3/27	64	24	24	72	1	-
369	41	4/41	64	28	56	32	-	1
371	21	2/21	64	24	56	32	-	1
372	27	3/27	64	-	-	48	2	1
373	20	2/20	72	32	48	40	-	1
374	27	3/27	56	32	64	72	1	-
375	27	3/27	40	-	-	24	2	1
377	29	3/29	24	-	-	24	1	2
378	27	3/27	64	-	-	32	2	1
379	20	2/20	72	40	56	48	-	1
381	27	3/27	56	-	-	24	2	1
382	20	2/20	72	-	-	40	1	2

TABLE of LEADS

Ratio of Head 1:40

Lead of Table Screw, $\frac{1}{4}$ inch (English)

Lead of Table Screw, 5 mm (Metric)

$$\text{Lead obtained} = \frac{10'' D \times B}{C \times A}$$

$$\text{Lead obtained} = \frac{200 \text{ mm } D \times B}{C \times A}$$

Change gear wheels provided: 24, 24, 28, 32, 40, 48, 56, 64, 72, 86, 100 teeth.

Use any gears as idlers to make up centre distance where necessary.

Two idlers or no idler gives right hand helix. One idler gives left hand helix.

The leads given in this table are obtained by driving through the worm gear reduction in the normal manner. For the cutting of very short leads refer to Page 19.

The Table of Leads is based on the use of a Dividing Head with the standard ratio of 1:40 and either a $\frac{1}{4}$ " pitch table screw for English Leads or a 5 mm pitch screw for Metric leads. The English and Metric leads resulting from the same change gear set-up are therefore not direct conversions.

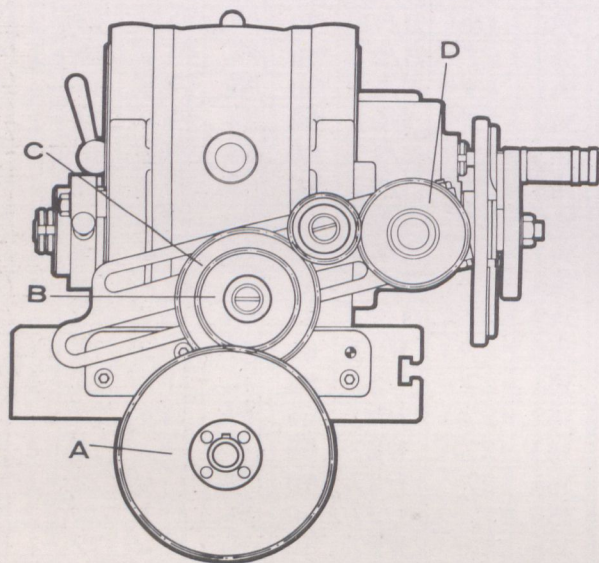

LEFT HAND DIVIDING HEAD

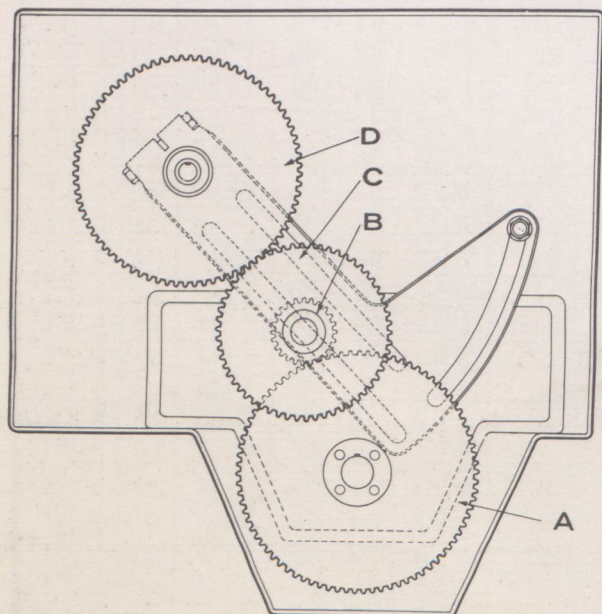

RIGHT HAND DIVIDING HEAD

Lead per one Revolution expressed in inches	Wheel on the Table Spindle A	Driven Wheels on the Change Gear Quadrant		Wheel on the Dividing Head D	Lead per one Revolution expressed in mm.
		B	C		
0.670	100	24	86	24	13.4
0.781	100	28	86	24	15.62
0.800	100	24	72	24	16.00
0.893	100	32	86	24	17.86
0.930	86	24	72	24	18.6
1.029	100	24	56	24	20.58
1.042	100	32	86	28	20.84
1.047	86	24	64	24	20.94
1.050	100	28	64	24	21.0
1.067	100	32	72	24	21.34
1.085	86	28	72	24	21.70
1.116	100	40	86	24	22.32
1.196	86	24	56	24	23.92
1.200	100	24	48	24	24.00
1.221	86	28	64	24	24.42
1.240	86	32	72	24	24.8
1.250	72	24	64	24	25.0
1.302	100	40	86	28	26.04
1.333	100	40	72	24	26.66
1.340	100	48	86	24	26.8
1.371	100	32	56	24	27.42
1.395	86	24	48	24	27.9
1.400	100	28	48	24	28.0
1.429	72	24	56	24	28.58
1.440	100	24	40	24	28.8
1.458	72	28	64	24	29.16
1.488	100	40	86	32	29.76
1.500	100	40	64	24	30.0
1.550	86	40	72	24	31.0
1.563	100	56	86	24	31.26

English leads based on $\frac{1}{4}$ " pitch table screw. Metric leads based on 5 mm pitch table screw
 Ratio of lead 1:40
 Two idlers or none produce right hand helix. One idler gives left hand helix
 Use any gears as idlers to make up centre distance as necessary
 CHANGE GEARS SUPPLIED 24, 24, 28, 32, 40, 48, 56, 64, 72, 86 and 100 teeth

Lead per one Revolution expressed in inches	Wheel on the Table Spindle			Wheel on the Dividing Head	Lead per one Revolution expressed in mm.	Lead per one Revolution expressed in inches	Wheel on the Table Spindle			Wheel on the Dividing Head	Lead per one Revolution expressed in mm.	Lead per one Revolution expressed in inches	Wheel on the Table Spindle			Wheel on the Dividing Head	Lead per one Revolution expressed in mm.
	A	B	C				A	B	C				A	B	C		
1.595	86	32	56	24	31.9	2.442	86	28	32	24	48.84	3.349	100	72	86	40	66.98
1.600	100	32	48	24	32.0	2.450	100	56	64	28	49.10	3.360	100	24	40	56	67.20
1.607	64	24	56	24	32.14	2.481	86	48	72	32	49.62	3.403	72	56	64	28	68.06
1.628	86	28	48	24	32.56	2.489	100	56	72	32	49.78	3.428	56	32	40	24	68.56
1.667	72	28	56	24	33.34	2.500	56	28	48	24	50.00	3.429	100	24	28	40	68.58
1.674	86	24	40	24	33.48	2.532	86	56	72	28	50.64	3.488	86	48	64	40	69.76
1.680	100	28	40	24	33.60	2.571	56	24	40	24	51.42	3.500	100	56	64	40	70.00
1.714	100	40	56	24	34.28	2.593	72	32	48	28	51.86	3.556	100	64	72	40	71.12
1.744	86	40	64	24	34.88	2.605	86	32	40	28	52.10	3.571	56	40	48	24	71.42
1.750	100	40	64	28	35.10	2.625	64	28	40	24	52.50	3.572	100	64	86	48	71.44
1.778	100	40	72	32	35.56	2.658	86	40	56	32	53.16	3.588	86	24	56	72	71.76
1.786	100	64	86	24	35.72	2.667	100	48	72	40	53.34	3.600	100	24	48	72	72.00
1.800	100	48	64	24	36.00	2.678	64	40	56	24	53.56	3.618	86	40	72	56	72.36
1.809	86	40	72	28	36.18	2.679	100	72	86	32	53.58	3.646	64	28	48	40	72.52
1.823	100	56	86	28	36.46	2.700	100	72	64	24	54.00	3.657	100	32	56	64	73.14
1.860	86	32	56	28	37.20	2.713	86	40	48	28	54.36	3.663	86	28	64	72	73.26
1.861	86	48	72	24	37.22	2.743	100	64	56	24	54.86	3.673	56	24	28	24	73.46
1.867	100	32	48	28	37.34	2.778	72	40	64	32	55.56	3.686	100	24	56	86	73.72
1.875	64	24	48	24	37.50	2.791	86	48	56	28	55.82	3.704	72	40	48	32	74.08
1.905	72	32	56	24	38.10	2.800	100	28	24	24	56.00	3.721	86	32	24	24	74.42
1.920	100	32	40	24	38.40	2.812	64	24	32	24	56.24	3.733	100	56	72	48	74.66
1.944	72	28	48	24	38.88	2.845	100	64	72	32	56.50	3.750	48	24	32	24	75.00
1.954	86	28	40	24	39.08	2.849	86	56	64	28	56.98	3.763	100	28	64	86	75.26
1.993	86	40	56	24	39.86	2.857	56	32	48	24	57.14	3.799	86	28	48	56	75.98
2.000	72	24	40	24	40.00	2.867	100	24	72	86	57.34	3.809	72	32	28	24	76.18
2.009	100	72	86	24	40.18	2.880	100	48	40	24	57.60	3.810	72	24	56	64	76.20
2.035	86	40	64	28	40.70	2.894	86	64	72	28	57.88	3.822	100	32	72	86	76.44
2.057	100	24	28	24	41.14	2.917	72	56	64	24	58.34	3.840	100	24	40	64	76.80
2.067	86	40	72	32	41.34	2.977	100	64	86	40	59.54	3.876	86	100	72	24	77.52
2.083	72	40	64	24	41.66	3.000	56	28	40	24	60.00	3.889	72	56	64	32	77.78
2.084	100	64	86	28	41.68	3.086	100	72	56	24	61.72	3.907	86	24	40	56	78.14
2.093	86	48	64	24	41.86	3.101	86	48	72	40	62.02	3.920	100	56	40	28	78.40
2.100	100	56	64	24	42.00	3.111	72	32	40	28	62.22	3.987	86	40	28	24	79.74
2.133	100	64	72	24	42.66	3.125	64	40	56	28	62.50	4.000	48	32	40	24	80.00
2.143	64	32	56	24	42.86	3.126	100	56	86	48	62.52	4.019	100	48	86	72	80.38
2.171	86	56	72	24	43.42	3.140	64	72	86	24	62.80	4.070	86	40	32	28	81.40
2.178	100	56	72	28	43.56	3.150	64	72	100	28	63.10	4.114	100	24	28	48	82.28
2.188	64	28	48	24	43.76	3.175	72	40	56	32	63.50	4.135	86	64	72	40	82.70
2.222	72	32	48	24	44.44	3.189	86	48	56	32	63.78	4.167	56	40	48	28	83.34
2.233	100	48	86	40	44.66	3.190	56	64	86	24	63.80	4.186	86	32	64	72	83.72
2.240	100	32	40	28	44.80	3.200	56	64	100	28	64.00	4.200	100	56	64	48	84.00
2.250	64	24	40	24	45.10	3.214	64	48	56	24	64.28	4.253	86	32	56	64	85.06
2.286	100	40	56	32	45.72	3.225	64	86	100	24	64.50	4.267	100	32	48	64	85.34
2.326	86	40	64	32	46.52	3.241	72	40	48	28	64.82	4.286	48	24	28	24	85.72
2.333	100	40	48	28	46.66	3.256	86	28	24	24	65.12	4.300	100	28	56	86	86.00
2.344	100	72	86	28	46.88	3.267	100	56	48	28	65.34	4.320	100	24	40	72	86.40
2.381	100	64	86	32	47.62	3.281	64	28	32	24	65.62	4.341	86	56	72	48	86.82
2.392	86	48	56	24	47.84	3.308	86	64	72	32	66.16	4.342	86	28	48	64	86.84
2.400	100	48	56	28	48.00	3.333	72	48	64	32	66.66	4.361	86	24	64	100	87.22
2.431	72	40	64	28	48.62	3.345	72	86	100	28	66.90	4.375	64	28	24	24	87.50

English leads based on $\frac{1}{4}$ " pitch table screw. Metric leads based on 5 mm pitch table screw
 Ratio of lead 1:40
 Two idlers or none produce right hand helix. One idler gives left hand helix
 Use any gears as idlers to make up centre distance as necessary
 CHANGE GEARS SUPPLIED 24, 24, 28, 32, 40, 48, 56, 64, 72, 86 and 100 teeth

Lead per one Revolution expressed in inches	Wheel on the Table Spindle			Wheel on the Dividing Head	Lead per one Revolution expressed in mm.	Lead per one Revolution expressed in inches	Wheel on the Table Spindle			Wheel on the Dividing Head	Lead per one Revolution expressed in mm.	Lead per one Revolution expressed in inches	Wheel on the Table Spindle			Wheel on the Dividing Head	Lead per one Revolution expressed in mm.
	A	B	C				A	B	C				A	B	C		
4.444	72	28	56	64	88.88	5.357	64	24	28	40	107.14	6.563	64	24	32	56	131.26
4.465	86	24	40	64	89.30	5.358	100	72	86	64	107.16	6.645	86	32	56	100	132.90
4.466	86	32	40	48	89.32	5.375	100	40	64	86	107.50	6.667	56	28	48	64	133.34
4.479	72	24	64	86	89.58	5.400	100	24	32	72	108.0	6.689	100	56	72	86	133.78
4.480	100	32	40	56	89.60	5.426	86	28	24	40	108.52	6.697	64	24	56	100	133.94
4.500	100	40	64	72	90.00	5.427	86	56	48	40	108.54	6.698	86	32	40	72	133.96
4.522	86	28	72	100	90.44	5.444	72	28	40	56	108.88	6.719	64	24	48	86	134.38
4.537	72	28	48	56	90.74	5.469	64	28	32	40	109.38	6.720	100	48	40	56	134.40
4.558	86	28	40	56	91.16	5.486	100	24	28	64	109.72	6.750	64	24	40	72	135.00
4.572	100	64	56	40	91.44	5.556	72	24	24	40	111.12	6.784	86	28	48	100	135.68
4.651	86	24	24	40	93.02	5.581	86	24	32	64	111.62	6.806	72	28	32	56	136.12
4.667	48	32	40	28	93.34	5.582	86	24	24	48	111.64	6.825	72	32	56	86	136.50
4.687	64	24	32	40	93.74	5.600	100	24	24	56	112.0	6.857	40	24	28	32	137.14
4.688	100	72	86	56	93.76	5.625	64	24	32	48	112.50	6.880	100	32	40	86	137.60
4.762	72	24	28	40	95.24	5.698	86	28	32	56	113.96	6.944	72	24	48	100	138.88
4.778	100	40	72	86	95.56	5.714	72	24	28	48	114.28	6.945	72	28	56	100	138.90
4.784	86	32	56	72	95.68	5.733	100	32	48	86	114.66	6.968	72	28	48	86	139.36
4.785	86	24	28	48	95.70	5.759	64	24	56	86	115.18	6.977	86	40	32	48	139.54
4.800	100	24	24	48	96.00	5.760	100	32	40	72	115.20	7.000	40	24	24	28	140.0
4.821	64	24	56	72	96.42	5.788	86	56	72	64	115.76	7.111	72	32	40	64	142.22
4.861	72	28	32	40	97.22	5.814	86	32	64	100	116.28	7.143	64	32	28	40	142.86
4.884	86	56	64	48	97.68	5.833	48	24	24	28	116.66	7.167	72	24	40	86	143.34
4.898	56	32	28	24	97.96	5.861	86	28	40	72	117.22	7.176	86	24	28	72	143.52
4.900	100	28	32	56	98.00	5.926	72	32	48	64	118.52	7.200	100	24	24	72	144.00
4.914	100	32	56	86	98.28	5.952	72	24	56	100	119.04	7.268	86	40	64	100	145.36
4.961	86	32	48	64	99.22	5.954	86	32	40	64	119.08	7.292	64	40	48	56	145.84
4.978	100	64	72	56	99.56	5.972	72	24	48	86	119.44	7.314	100	32	28	64	146.28
4.984	86	24	56	100	99.68	5.980	86	40	56	72	119.60	7.326	86	28	32	72	146.52
5.000	56	28	24	24	100.00	6.000	56	28	40	48	120.00	7.347	56	24	28	48	146.94
5.017	100	28	48	86	100.34	6.020	100	28	40	86	120.40	7.371	100	48	56	86	147.42
5.023	86	24	40	72	100.46	6.077	72	28	64	100	121.54	7.372	100	24	28	86	147.44
5.040	100	28	40	72	100.80	6.122	56	24	28	40	122.44	7.408	72	32	24	40	148.16
5.080	72	32	56	64	101.60	6.125	64	28	40	56	122.50	7.442	86	24	24	64	148.84
5.088	86	28	64	100	101.76	6.143	100	40	56	86	122.86	7.465	72	40	64	86	149.30
5.105	64	56	48	28	102.10	6.171	100	48	56	72	123.42	7.467	100	28	24	64	149.34
5.119	72	24	56	86	102.38	6.172	100	24	28	72	123.44	7.500	64	24	24	48	150.0
5.120	100	32	40	64	102.40	6.202	86	32	24	40	124.04	7.525	100	28	32	86	150.5
5.142	100	40	56	72	102.84	6.222	72	28	40	64	124.44	7.597	86	28	24	56	151.94
5.143	40	24	28	24	102.86	6.250	64	40	24	24	125.00	7.619	56	32	48	64	152.38
5.160	100	24	40	86	103.20	6.279	86	48	64	72	125.58	7.020	72	24	28	64	152.40
5.168	86	32	72	100	103.36	6.300	100	28	32	72	126.00	7.644	100	64	72	86	152.88
5.185	72	32	24	28	103.70	6.350	72	32	28	40	127.00	7.657	64	28	32	56	153.14
5.186	72	28	48	64	103.72	6.379	86	24	28	64	127.58	7.679	56	24	48	86	153.58
5.209	72	24	64	100	104.18	6.400	100	24	24	64	128.00	7.680	100	48	40	64	153.60
5.210	86	28	40	64	104.20	6.429	32	24	28	24	128.58	7.714	56	24	40	72	154.28
5.226	72	28	64	86	104.52	6.450	100	48	64	86	129.00	7.752	86	32	48	100	155.04
5.233	86	40	64	72	104.66	6.460	86	40	72	100	129.20	7.778	48	28	24	32	155.56
5.250	40	28	32	24	105.00	6.482	72	40	48	56	129.64	7.813	64	24	48	100	156.26
5.316	86	32	28	40	106.32	6.512	86	24	24	56	130.24	7.815	86	48	40	56	156.30
5.333	100	32	24	40	106.66	6.534	100	28	24	56	130.68	7.838	64	28	48	86	156.76

English leads based on $\frac{1}{4}$ " pitch table screw. Metric leads based on 5 mm pitch table screw
 Ratio of lead 1:40
 Two idlers or none produce right hand helix. One idler gives left hand helix.
 Use any gears as idlers to make up centre distance as necessary
 CHANGE GEARS SUPPLIED 24, 24, 28, 32, 40, 48, 56, 64, 72, 86 and 100 teeth

Lead per one Revolution expressed in inches	Wheel on the Table Spindle A	Driven Wheels on the Change Gear Quadrant		Wheel on the Dividing Head D	Lead per one Revolution expressed in mm.	Lead per one Revolution expressed in inches	Wheel on the Table Spindle A	Driven Wheels on the Change Gear Quadrant		Wheel on the Dividing Head D	Lead per one Revolution expressed in mm.	Lead per one Revolution expressed in inches	Wheel on the Table Spindle A	Driven Wheels on the Change Gear Quadrant		Wheel on the Dividing Head D	Lead per one Revolution expressed in mm.
		B	C					B	C					B	C		
7.875	64	28	40	72	157.50	9.598	64	40	56	86	191.96	11.250	64	24	24	72	225.00
7.936	72	32	56	100	158.72	9.600	100	32	24	72	192.00	11.429	28	24	24	32	228.58
7.963	72	32	48	86	159.26	9.643	56	24	32	72	192.86	11.467	100	32	24	86	229.34
7.974	86	40	28	48	159.48	9.675	100	72	64	86	193.50	11.518	64	24	28	86	230.36
8.000	100	40	32	64	160.0	9.690	86	40	48	100	193.80	11.520	100	64	40	72	230.40
8.035	64	40	56	72	160.70	9.723	48	28	24	40	194.46	11.574	72	40	48	100	231.48
8.063	64	24	40	86	161.26	9.768	86	56	48	72	195.36	11.629	86	24	24	100	232.58
8.102	72	28	48	100	162.04	9.796	56	24	28	64	195.92	11.667	48	24	24	56	233.34
8.140	86	40	32	56	162.80	9.828	100	32	28	86	196.56	11.719	64	24	32	100	234.38
8.163	56	32	28	40	163.26	9.844	64	28	32	72	196.88	11.721	86	56	40	72	234.42
8.167	48	28	40	56	163.34	9.921	72	40	56	100	198.42	11.757	64	28	32	86	235.14
8.229	100	32	28	72	164.58	9.923	86	32	24	64	198.46	11.905	72	24	28	100	238.10
8.306	86	40	56	100	166.12	9.954	72	40	48	86	199.08	11.944	72	24	24	86	238.88
8.333	48	24	24	40	166.66	9.967	86	48	56	100	199.34	11.960	86	40	28	72	239.20
8.334	56	28	24	40	166.68	9.968	86	24	28	100	199.36	12.000	40	24	24	48	240.00
8.361	72	28	40	86	167.22	10.000	48	24	28	56	200.0	12.040	100	56	40	86	240.80
8.372	86	24	24	72	167.44	10.033	100	28	24	86	200.66	12.153	72	28	32	100	243.06
8.400	100	28	24	72	168.00	10.046	86	48	40	72	200.92	12.245	56	40	28	48	244.90
8.437	64	24	32	72	168.74	10.078	64	24	32	86	201.56	12.250	40	28	32	56	245.00
8.506	86	32	28	64	170.12	10.080	100	56	40	72	201.60	12.286	100	40	28	86	245.72
8.532	72	40	56	86	170.64	10.159	72	32	28	64	203.18	12.343	100	48	28	72	246.86
8.534	100	32	24	64	170.68	10.175	86	28	32	100	203.50	12.403	86	40	24	64	248.06
8.572	56	24	32	64	171.44	10.209	64	28	24	56	204.18	12.444	72	56	40	64	248.88
8.572	56	24	24	48	171.44	10.238	72	24	28	86	204.76	12.500	32	24	24	40	250.00
8.600	100	24	24	86	172.00	10.286	40	24	28	48	205.72	12.542	48	28	40	86	250.84
8.640	100	48	40	72	172.80	10.320	100	48	40	86	206.40	12.558	86	48	32	72	251.16
8.681	72	40	64	100	173.62	10.336	86	64	72	100	206.72	12.600	100	56	32	72	252.00
8.682	86	28	24	64	173.64	10.370	72	28	24	64	207.40	12.698	72	40	28	64	253.96
8.721	86	24	32	100	174.42	10.371	72	56	48	64	207.42	12.758	86	48	28	64	255.16
8.750	32	24	24	28	175.0	10.417	72	24	32	100	208.34	12.798	56	40	48	86	255.96
8.929	56	24	48	100	178.58	10.419	86	56	40	64	208.38	12.800	100	56	28	64	256.00
8.930	86	48	40	64	178.60	10.451	72	28	32	86	209.02	12.857	64	32	28	72	257.14
8.959	56	28	48	86	179.18	10.467	86	40	32	72	209.34	12.858	32	24	28	48	257.16
8.960	100	56	40	64	179.20	10.500	40	24	32	56	210.00	12.900	100	48	32	86	258.00
9.000	40	24	32	48	180.0	10.631	86	40	28	64	212.62	12.963	72	40	24	56	259.26
9.044	86	56	72	100	180.88	10.667	72	48	40	64	213.34	13.020	64	40	48	100	260.40
9.074	72	28	24	56	181.48	10.713	32	24	28	40	214.26	13.024	86	48	24	56	260.48
9.115	64	28	48	100	182.30	10.714	56	40	32	48	214.28	13.062	56	32	28	64	261.24
9.143	56	32	40	64	182.86	10.750	48	24	40	86	215.00	13.082	86	72	64	100	261.64
9.214	56	24	40	86	184.28	10.800	100	48	32	72	216.00	13.125	48	28	32	72	262.50
9.260	72	32	48	100	185.20	10.853	86	40	24	56	217.06	13.163	56	24	28	86	263.26
9.302	86	40	24	48	186.04	10.937	64	40	32	56	218.74	13.289	86	32	28	100	265.78
9.303	86	40	28	56	186.06	10.972	100	48	28	64	219.44	13.333	48	24	24	64	266.66
9.333	48	28	40	64	186.66	11.021	56	24	28	72	220.42	13.393	64	48	56	100	267.86
9.334	40	28	24	32	186.68	11.057	100	72	56	86	221.14	13.396	86	64	40	72	267.92
9.375	64	40	32	48	187.50	11.111	48	32	24	40	222.22	13.437	56	28	32	86	268.74
9.406	64	28	40	86	188.12	11.160	64	40	56	100	223.20	13.438	64	24	24	86	268.76
9.524	48	32	28	40	190.48	11.163	86	32	24	72	223.26	13.500	40	24	32	72	270.00
9.556	72	32	40	86	191.12	11.198	64	40	48	86	223.96	13.566	86	28	24	100	271.32
9.569	86	32	28	72	191.38	11.200	100	48	24	56	224.00	13.611	48	28	24	56	272.22

English leads based on $\frac{1}{4}$ " pitch table screw. Metric leads based on 5 mm pitch table screw

Ratio of lead 1:40

Two idlers or none produce right hand helix. One idler gives left hand helix

Use any gears as idlers to make up centre distance as necessary

CHANGE GEARS SUPPLIED 24, 24, 28, 32, 40, 48, 56, 64, 72, 86 and 100 teeth

Lead per one Revolution expressed in inches	Wheel on the Table Spindle		Driven Wheels on the Change Gear Quadrant		Wheel on the Dividing Head	Lead per one Revolution expressed in mm.	Lead per one Revolution expressed in inches	Wheel on the Table Spindle		Driven Wheels on the Change Gear Quadrant		Wheel on the Dividing Head	Lead per one Revolution expressed in mm.	Lead per one Revolution expressed in inches	Wheel on the Table Spindle		Driven Wheels on the Change Gear Quadrant		Wheel on the Dividing Head	Lead per one Revolution expressed in mm.
	A	B	C	D				A	B	C	D				A	B	C	D		
13.650	72	32	28	86		273.00	16.333	40	28	24	56		326.66	19.687	64	56	32	72		393.74
13.672	64	28	32	100		273.44	16.456	100	64	28	72		329.12	19.840	72	40	28	100		396.80
13.713	56	48	40	64		274.26	16.612	86	40	28	100		332.24	19.908	72	40	24	86		398.16
13.715	40	24	28	64		274.30	16.667	48	40	28	56		333.34	19.934	86	48	28	100		398.68
13.760	100	64	40	86		275.20	16.722	72	56	40	86		334.44	20.00	48	32	24	72		400.0
13.889	72	24	24	100		277.78	16.744	86	48	24	72		334.88	20.07	100	56	24	86		401.4
13.933	72	56	48	86		278.66	16.797	64	40	32	86		335.94	20.09	64	72	56	100		401.8
13.935	72	28	24	86		278.70	16.800	100	56	24	72		336.00	20.16	64	72	48	86		403.2
13.953	86	40	24	72		279.06	16.875	64	48	32	72		337.50	20.35	86	56	32	100		407.0
14.000	40	24	24	56		280.00	17.062	72	40	28	86		341.24	20.41	56	32	28	100		408.2
14.063	64	40	32	72		281.26	17.141	56	48	32	64		342.82	20.42	32	28	24	56		408.4
14.286	28	24	24	40		285.72	17.143	32	24	28	64		342.86	20.48	56	64	48	86		409.6
14.333	48	32	40	86		286.66	17.144	28	24	24	48		342.88	20.57	56	64	40	72		411.4
14.352	86	48	28	72		287.04	17.200	100	64	32	86		344.00	20.74	72	56	24	64		414.8
14.400	100	48	24	72		288.00	17.275	64	72	56	86		345.50	20.83	72	48	32	100		416.6
14.536	86	40	32	100		290.72	17.361	72	40	32	100		347.22	20.90	72	56	32	86		418.0
14.583	48	40	32	56		291.66	17.364	86	56	24	64		347.28	20.93	86	72	40	100		418.6
14.584	32	28	24	40		291.68	17.442	86	48	32	100		348.84	21.00	40	48	32	56		420.0
14.651	86	56	32	72		293.02	17.500	32	24	24	56		350.00	21.33	72	86	56	100		426.6
14.694	56	32	28	72		293.88	17.550	56	32	28	86		351.00	21.43	56	48	40	100		428.6
14.743	100	48	28	86		294.86	17.778	48	32	24	64		355.56	21.50	40	24	24	86		430.0
14.815	72	40	24	64		296.30	17.858	56	24	24	100		357.16	21.88	64	56	40	100		437.6
14.880	56	40	48	100		297.60	17.917	64	32	24	86		358.34	21.94	56	40	28	86		438.8
14.884	86	56	28	64		297.68	17.918	48	24	24	86		358.36	22.04	56	48	28	72		440.8
14.931	72	40	32	86		298.62	18.000	40	24	24	72		360.00	22.11	100	72	28	86		442.2
14.933	100	56	24	64		298.66	18.229	48	28	32	100		364.58	22.22	72	64	40	100		444.4
14.950	86	72	56	100		299.00	18.285	40	32	28	64		365.70	22.40	48	40	32	86		448.0
15.000	32	24	24	48		300.00	18.367	56	40	28	72		367.34	22.50	64	48	24	72		450.0
15.050	100	56	32	86		301.00	18.428	40	24	28	86		368.56	22.86	28	24	24	64		457.2
15.238	72	48	28	64		304.76	18.519	72	32	24	100		370.38	22.93	100	64	24	86		458.6
15.239	48	32	28	64		304.78	18.605	86	64	40	100		372.10	23.04	48	72	56	86		460.8
15.306	56	24	28	100		306.12	18.663	72	86	64	100		373.26	23.14	72	40	24	100		462.8
15.357	48	24	28	86		307.14	18.667	40	28	24	64		373.34	23.26	86	64	32	100		465.2
15.429	56	48	40	72		308.58	18.750	40	24	32	100		375.00	23.33	48	56	32	64		466.6
15.480	100	72	40	86		309.60	18.750	48	40	32	72		375.00	23.44	64	72	48	100		468.8
15.504	86	64	48	100		310.08	18.812	40	28	32	86		376.24	23.52	64	56	32	86		470.4
15.556	72	56	32	64		311.12	19.048	28	32	24	40		380.96	23.81	56	64	48	100		476.2
15.625	64	24	24	100		312.50	19.111	72	64	40	86		382.22	23.89	72	64	32	86		477.8
15.677	48	28	32	86		313.54	19.136	86	64	28	72		382.72	24.00	48	72	40	64		480.0
15.750	40	28	32	72		315.00	19.197	56	40	32	86		383.94	24.19	64	72	40	86		483.8
15.873	72	64	56	100		317.46	19.200	100	64	24	72		384.00	24.31	72	56	32	100		486.2
15.874	72	32	28	100		317.48	19.285	56	48	32	72		385.70	24.57	56	64	40	86		491.4
15.925	72	64	48	86		318.50	19.286	32	24	28	72		385.72	24.88	48	86	72	100		497.6
15.926	72	32	24	86		318.52	19.350	100	72	32	86		387.00	25.00	48	40	24	72		500.0
16.000	40	24	24	64		320.00	19.380	86	40	24	100		387.60	25.08	40	28	24	86		501.6
16.071	56	40	32	72		321.42	19.444	24	28	24	40		388.88	25.09	48	56	40	86		501.8
16.125	40	24	32	86		322.50	19.531	64	40	32	100		390.62	25.51	56	40	28	100		510.2
16.204	72	28	24	100		324.08	19.535	86	56	24	72		390.70	25.60	48	40	28	86		512.0
16.280	86	56	40	100		325.60	19.590	56	48	28	64		391.80	25.71	56	48	24	72		514.2
16.327	56	40	28	64		326.54	19.656	100	64	28	86		393.12	25.72	28	24	24	72		514.4

English leads based on $\frac{1}{4}$ " pitch table screw. Metric leads based on 5 mm pitch table screw.
 Ratio of lead 1:40
 Two idlers or none produce right hand helix. One idler gives left hand helix
 Use any gears as idlers to make up centre distance as necessary
 CHANGE GEARS SUPPLIED 24, 24, 28, 32, 40, 48, 56, 64, 72, 86 and 100 teeth

Lead per one Revolution expressed in inches	Wheel on the Table Spindle			Wheel on the Dividing Head	Lead per one Revolution expressed in mm.	Lead per one Revolution expressed in inches	Wheel on the Table Spindle			Wheel on the Dividing Head	Lead per one Revolution expressed in mm.	Lead per one Revolution expressed in inches	Wheel on the Table Spindle			Wheel on the Dividing Head	Lead per one Revolution expressed in mm.
	A	B	C				A	B	C				A	B	C		
25.80	100	72	24	86	516.0	34.55	56	72	32	86	691.0	48.38	40	72	32	86	967.6
26.04	48	40	32	100	520.8	34.72	48	40	24	100	694.4	48.61	48	56	24	100	972.2
26.16	86	72	32	100	523.2	34.88	86	72	24	100	697.6	49.14	40	64	28	86	982.8
26.25	48	56	32	72	525.0	35.00	48	56	24	72	700.0	49.77	72	86	24	100	995.4
26.33	56	48	28	86	526.6	35.10	56	64	28	86	702.0	50.00	40	56	28	100	1000.0
26.58	86	64	28	100	531.6	35.16	64	72	32	100	703.2	50.17	40	56	24	86	1003.4
26.67	48	56	28	64	533.4	35.56	24	32	24	64	711.2	51.19	28	40	24	86	1023.8
26.79	56	72	48	100	535.8	35.71	56	64	32	100	714.2	51.43	32	64	28	72	1028.6
26.88	64	56	28	86	537.6	35.72	28	24	24	100	714.4	52.50	32	56	24	72	1050.0
27.00	40	48	32	72	540.0	35.83	48	64	32	86	716.6	53.33	28	56	24	64	1066.6
27.13	86	56	24	100	542.6	36.00	40	64	32	72	720.0	53.57	48	72	28	100	1071.4
27.22	24	28	24	56	544.4	36.46	32	56	48	100	729.2	53.75	32	48	24	86	1075.0
27.30	72	64	28	86	546.0	36.86	40	48	28	86	737.2	54.85	56	86	28	100	1097.0
27.34	64	56	32	100	546.8	37.04	72	64	24	100	740.8	55.28	40	72	28	86	1105.6
27.43	40	48	28	64	548.6	37.33	72	86	32	100	746.6	55.56	24	32	24	100	1111.2
27.64	56	72	40	86	552.8	37.50	40	72	48	100	750.0	55.99	64	86	24	100	1119.8
27.78	72	64	32	100	555.6	37.63	40	56	32	86	752.6	56.25	40	72	32	100	1125.0
27.87	72	56	24	86	557.4	38.10	28	40	24	64	762.0	57.14	40	64	28	100	1142.8
28.00	48	86	64	100	560.0	38.39	56	86	40	100	767.8	57.33	40	64	24	86	1146.6
28.13	64	72	40	100	562.6	38.57	32	48	28	72	771.4	58.33	40	56	24	100	1166.6
28.57	40	64	56	100	571.4	38.89	24	40	24	56	777.8	59.53	28	40	24	100	1190.6
28.67	48	64	40	86	573.4	39.49	56	72	28	86	789.8	60.00	32	64	24	72	1200.0
29.17	48	56	40	100	583.4	40.00	48	64	24	72	800.0	61.43	28	48	24	86	1228.6
29.39	56	64	28	72	587.8	40.18	56	72	32	100	803.6	62.22	24	56	24	64	1244.4
29.76	48	40	28	100	595.2	40.31	48	72	32	86	806.2	62.50	32	48	24	100	1250.0
29.86	72	86	40	100	597.2	40.82	56	64	28	100	816.4	62.71	32	56	24	86	1254.2
29.90	86	72	28	100	598.0	40.95	48	64	28	86	819.0	63.99	56	86	24	100	1279.8
30.00	32	48	28	56	600.0	40.96	28	32	24	86	819.2	64.29	40	72	28	100	1285.8
30.23	64	72	32	86	604.6	41.14	40	64	28	72	822.8	64.50	40	72	24	86	1290.0
30.48	28	32	24	64	609.6	41.67	48	64	32	100	833.4	66.67	40	64	24	100	1333.4
30.61	56	48	28	100	612.2	41.81	48	56	24	86	836.2	67.19	40	86	32	100	1343.8
30.71	56	48	24	86	614.2	41.99	64	86	32	100	839.8	68.57	28	64	24	72	1371.4
30.72	28	24	24	86	614.4	42.00	40	56	24	72	840.0	69.11	32	72	28	86	1382.2
30.86	40	48	28	72	617.2	42.66	72	86	28	100	853.2	69.44	24	40	24	100	1388.8
31.01	86	64	24	100	620.2	42.86	40	48	28	100	857.2	70.00	24	56	24	72	1400.0
31.11	48	56	24	64	622.2	43.00	40	64	32	86	860.0	71.43	28	48	24	100	1428.6
31.25	64	56	28	100	625.0	43.75	40	56	32	100	875.0	71.67	24	48	24	86	1433.4
31.35	48	56	32	86	627.0	44.44	24	40	24	64	888.8	72.92	32	56	24	100	1458.4
31.36	32	28	24	86	627.2	44.64	32	40	28	100	892.8	74.65	48	86	24	100	1493.0
31.50	40	56	32	72	630.0	44.79	48	86	40	100	895.8	75.00	40	72	24	100	1500.0
31.75	28	64	72	100	635.0	45.00	32	56	28	72	900.0	76.39	24	44	24	100	1527.8
31.85	72	64	24	86	637.0	45.72	28	48	24	64	914.4	76.77	40	86	28	100	1535.4
31.99	48	86	56	100	639.8	45.92	56	72	28	100	918.4	80.00	24	64	24	72	1600.0
32.00	40	56	28	64	640.0	46.07	48	72	28	86	921.4	80.36	32	72	28	100	1607.2
32.14	40	72	56	100	642.8	46.67	32	56	24	64	933.4	80.63	32	72	24	86	1612.6
32.25	40	72	48	86	645.0	46.88	48	72	32	100	937.6	81.91	28	64	24	86	1638.2
32.41	72	56	24	100	648.2	47.62	48	64	28	100	952.4	83.33	24	48	24	100	1666.6
33.33	40	32	24	100	666.6	47.78	48	64	24	86	955.6	83.61	24	56	24	86	1672.2
33.59	40	86	64	100	671.8	47.99	56	86	32	100	959.8	89.58	40	86	24	100	1791.6
34.29	28	64	48	72	685.8	48.00	40	64	24	72	960.0	92.14	28	72	24	86	1842.8

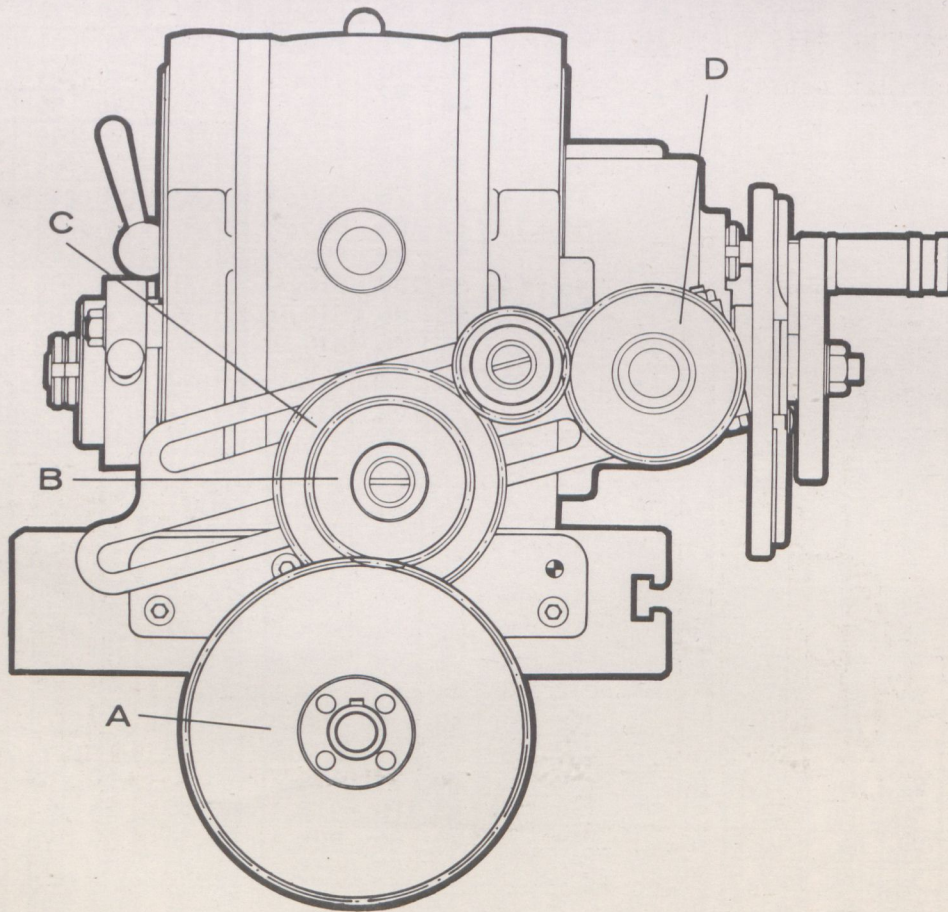
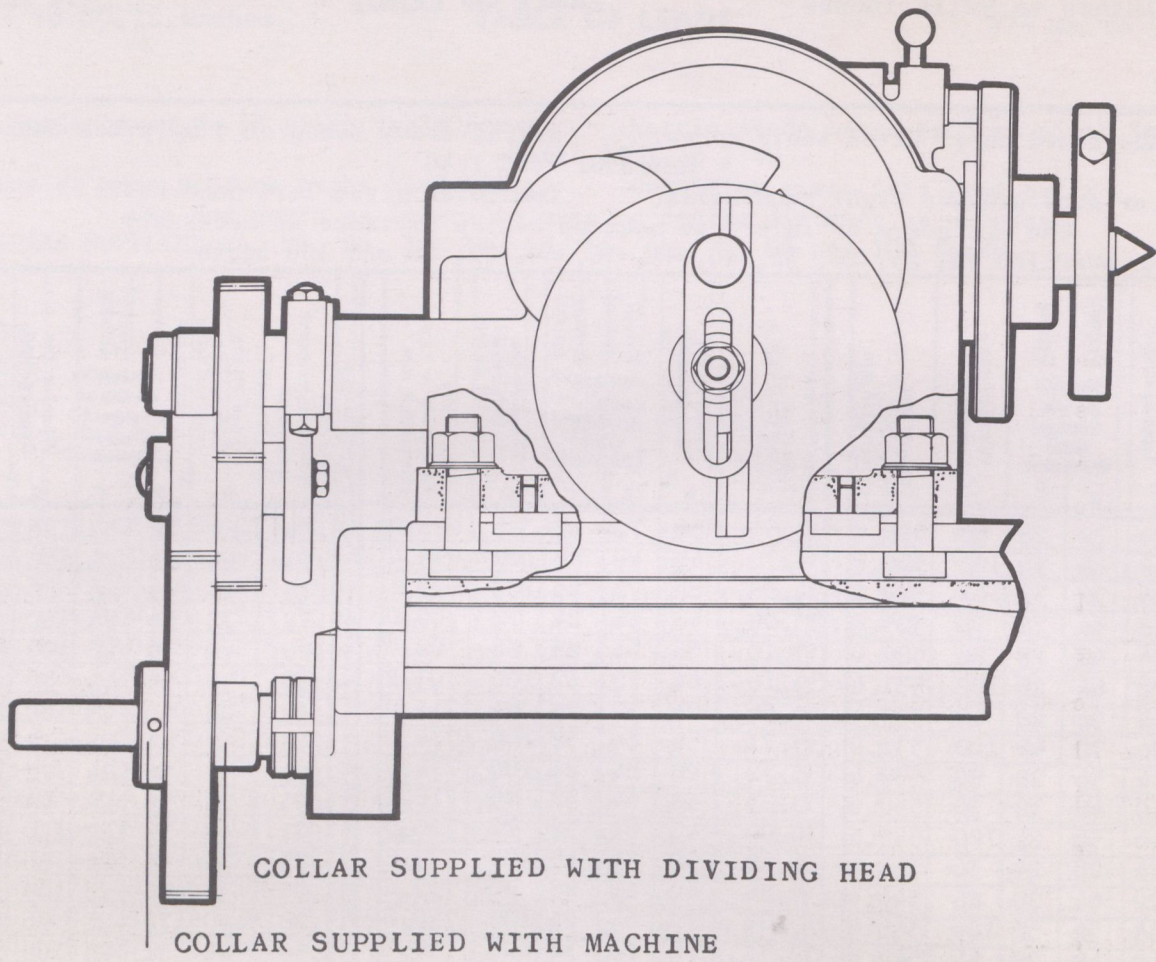

METHOD OF MOUNTING LEFT HAND DIVIDING HEAD
ON TO MILLING MACHINE TABLE

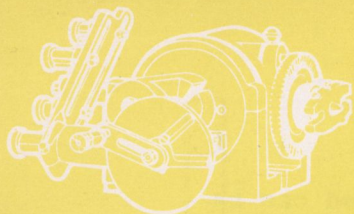

As the name implies the first function of a Dividing Head is to be able to re-position the work piece by rotating it through a given angle, or through a definite fraction of a complete circle so that if the operation is repeated a succession of equally spaced slots or holes can be machined in it.

DIRECT INDEXING - Although of limited application this is the simplest of all methods, in that an indexing plunger engages directly a disc mounted on the work spindle itself and having a circle of equally spaced holes or slots. The Elliott 9", 10" and 12" Universal Dividing Heads incorporate this feature, the disc having 24 holes so that this number of spaces, or any factor of 24 can be obtained direct.

Before applying direct indexing, move lever L1 (Fig.2) to the out position, thus disengaging worm W (Fig.2) from worm wheel WW (Fig.2).

It is good practice to remove the direct indexing plate when it is not being used, so that conflicting movements cannot be attempted simultaneously

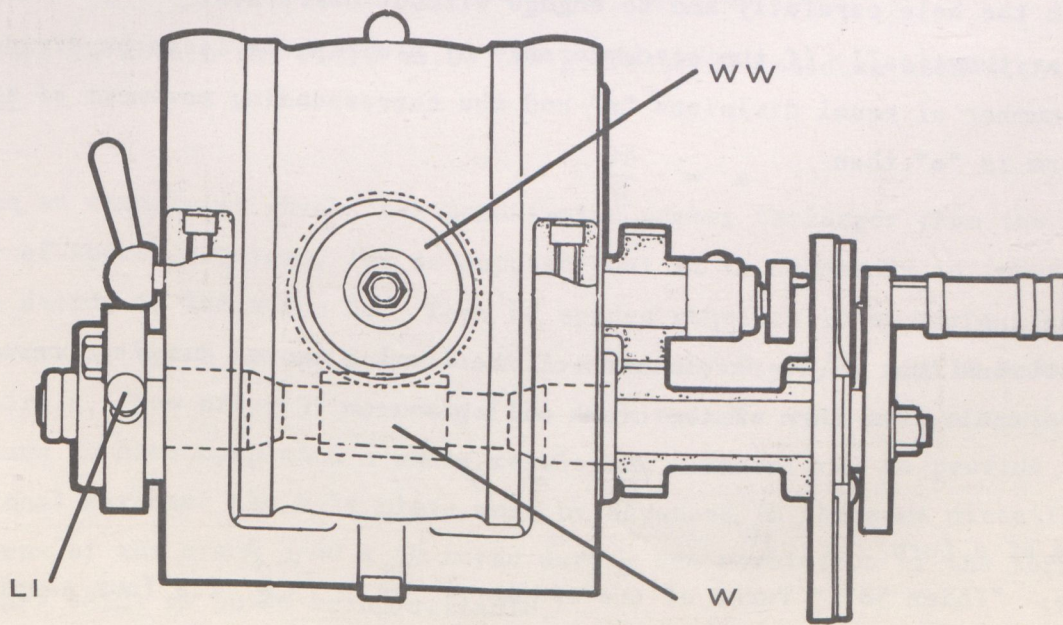

FIGURE 2

INDIRECT INDEXING - If the desired movement of the dividing head can be obtained merely by turning the crank from one position on the hole plate to another whilst the plate is locked stationary this is called plain or simple indexing. The calculations involved are very simple. Suppose it is required to cut a gear having 23 equally spaced slots in a cylindrical component. The standard worm-gear ratio is 40:1, so one complete revolution of the work spindle requires 40 turns of the crank. Therefore, to turn the spindle 1/23rd part of a revolution requires 40/23 or 1.73913 revolutions of the crank. The usual standard hole-plates have circles containing the following numbers of holes:

15	16	17	18	19	20
21	23	27	29	31	33
37	39	41	43	47	49

By using the second of the plates, adjusting the radius of the crank plunger to the 23 holes circle, and setting the sector arm for 17 holes, one can proceed to simple index the 23 spaces, moving the crank one complete turn plus the 17 holes at each movement. In this as in all indexing, care must be taken to avoid inaccuracy due to backlash. If, when moving the crank, the operator accidentally overshoots the hole which he intends to engage, the crank should be moved back a considerable amount and then brought forward again so as to approach the hole carefully and to engage without overtravel.

Stated arithmetically if the circumference of a workpiece is to be divided into a number of equal divisions "n" and the corresponding movement of the crank arm is "a" then

$$a = \frac{40}{n}$$

Indexing Angles

It is obvious that as 40 revolutions of the crank give one complete revolution of the spindle, one turn of the crank will give:

$$\frac{360}{40} = 9^\circ$$

and 1/9 of a turn = 1°

Example: "Index 38°." Turns of the crank = $\frac{38}{9} = 4 \frac{2}{9}$ i.e four complete turns of crank

and 2° (four holes in an 18 hole circle giving 2°)

To index to minutes. One turn of the crank = 9 x 60 = 540 mins.

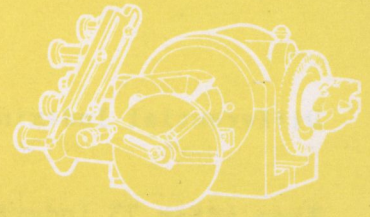

Differential Indexing is normally used when a particular number of divisions cannot be obtained by simple indexing. Let us take for example 61 spaces which number does not appear in our simple indexing table on Page 4.

To simple index we require to make $40/61$ turns of the crank which cannot be done with standard plates. We choose a number close to that which we wish to index, e.g 60 spaces. This would require $40/60$ turns of the crank which can be achieved by taking 10 holes on the 15-hole circle or various obvious alternatives. After 61 movements of the crank the work spindle would have moved $1/60$ th of a turn beyond the complete circle, therefore gearing must be arranged to transmit from the work spindle a suitable reverse movement to the hole plate so as to counterbalance the overtravel.

To remove $1/60$ th of a revolution of overtravel will require $1/60 \times 40$ revs of movement of the hole plate, on account of the worm gear ratio. A gear ratio of 40:60 is thus required between the work spindle and hole plate. The change gears supplied with dividing heads usually have the following numbers of teeth:

24	24	28	32	40	
48	56	64	72	86	100

Therefore to obtain the ratio 40:60 the gears 48/72 could be used with suitable idlers.

To take an example in which the approximated number is larger than the actual number of spaces required, let us suppose that it is necessary to index 57 spaces and we decide to index for 60. Then 60 spaces requires $40/60$ turns of the crank per movement, which we can do quite well since $40/60 = 2/3$, e.g 12 holes on the 18 hole circle. Now after 57 movements the work spindle will need a further $3/60$ th of a turn to have completed a whole revolution. Therefore, to provide this additional movement the hole plate must be advanced in the same direction as the turns of the crank $3/60 \times 40$ turns during one revolution of the work spindle, the gears 48:24 or 56:28 being suitable.

In these examples it has been possible to obtain the differential gearing by single train and idlers. To take an example where compound gearing is required, assume 73 spaces are required and it is decided to adopt 75 as the approximation.

Differential Indexing (continued)

Then after 73 indexings a further $2/75$ th of a revolution would require to be added to the movement of work spindle to complete the cycle. To supply this the differential gearing would be $2/75 \times 40 = 80/75$. This cannot be done by a single train of the standard wheels, so, factorizing, we obtain

$$\frac{80}{75} = \frac{16}{15} = \frac{4}{3} \times \frac{4}{5} \quad \text{for which we can use } \frac{64}{48} \times \frac{32}{40}$$

The required gearing ratio can be evaluated by the formula:

$$\text{Differential gearing ratio} = (A - B) \times \frac{40}{B}$$

where A = The actual number of divisions required.

B = The number chosen for indexing purposes.

If B should be larger than A the formula becomes

$$\text{Differential gearing ratio} = (B - A) \times \frac{40}{B}$$

DETERMINATION OF NUMBER OF IDLERS. If the selected number is greater than the actual number of divisions required, then the gearing must drive the hole plate in the same direction as the crank movements. To do this a simple gear will require one idler and a compound gear no idler.

If the selected number is less than the actual number of divisions required, then the gearing must drive the hole plate in the opposite direction to the crank movements. To do this a simple gear will require two idlers and a compound gear one idler.

BLOCK INDEXING. In the examples which we have used it has been assumed that the spaces would be cut consecutively. With the block system, however, which is occasionally used in gear cutting the work is indexed an amount equal to several spaces between cuts. Thus a 17 tooth gear might be cut by indexing the 1st, 4th, 7th, 10th, 13th and 16th spaces and then continuing the process for a second revolution to cut the 2nd, 5th, 8th etc. until after nearly three revolutions the job is completed. The method is sometimes helpful when cutting cast iron gears in one pass since the heat generated is distributed more evenly along the circumference.

LOW LEAD ATTACHMENT

FOR MILLING LEADS DOWN TO 0.050" or 1 mm

WHERE THE WORK DIAMETER DOES NOT EXCEED 12 TIMES THE PITCH

The conventional set-ups for generating leads below 2" on English Machines or 40 mm with metric screws, demand a 'pick-up' of 5:1 or more in the drive from the machine table to the Dividing Head worm and this can result in heavy binding loads in the change gears, sometimes making it necessary to disengage the power feed and perform the operation by manual rotation of the Dividing Head crank, so that the table movement is actually transmitted back from the head through what is now a reducing gear train.

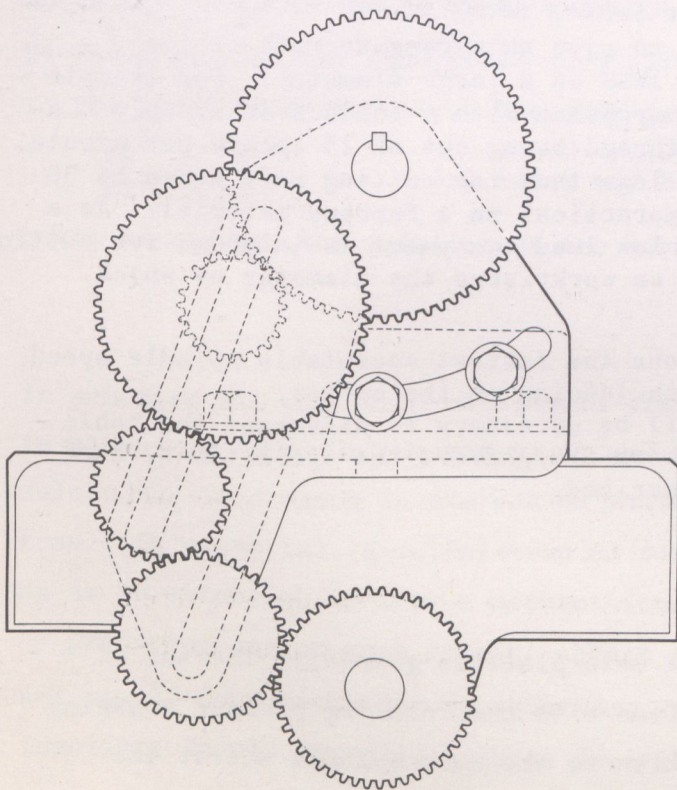

FIGURE 3

With this arrangement the drive from the table screw is transmitted through the standard change gears directly to the work spindle, and not through the worm gear. Therefore, the worm must be disengaged when using this attachment. The result is that a change gear set-up of 5:1 which would normally produce a lead of 2" on English machines, now gives a lead of 0.050", (5 turns of the work spindle for one revolution of the $\frac{1}{4}$ " pitch table screw). Conversely, a lead of 2" can be produced with change gears set-up to give a reduction of 1:8 instead of a pick-up of 5:1 this resulting in much better operating conditions.

There are on the market, some very expensive devices, which have been designed to overcome this problem, but subject to certain limitations as described below, the ELLIOTT low lead attachment shown in Fig.3 increases the scope of the standard equipment for a very modest cost.

SHORT LEAD ATTACHMENT (continued)

The operator should note the following points when setting up for short leads:-

- 1 If the lead angle of any thread which is to be cut with a gashing cutter is less than 45° , this cannot be accommodated by swivelling the universal saddle of the milling machine. The correct practice is to use a universal milling head because this can be set to any angle from zero to 90° whilst the worktable remains square with the machine knee and column (Fig.4)
- 2 When attempting to cut low leads either with a normal dividing head set-up or with the help of the ELLIOTT low lead attachment, it is necessary to consider the resulting feed rate. Even the slowest feed rate available for driving the machine table is likely to give an excessive rate at the cutter if the work involves a short lead on a large diameter. For example - to cut a $\frac{1}{8}$ " lead on a $1\frac{1}{2}$ " diameter workpiece with a table feed of only 0.4 inches per minute - results in the thread being cut at 15 inches per minute. If the diameter were 3 inches it follows that the cutting rate would be 30 inches per minute, which would be impractical on a ferrous material. As a general rule therefore, the ELLIOTT low lead equipment is intended for cutting pitches down to 0.05 inches or 1 mm on workpieces the diameter of which does not exceed 12 times the pitch.
- 3 In order to obtain the best conditions the fastest acceptable spindle speed should be used, so reducing the tooth loading on the cutter. If the problem still persists it will be necessary to disengage the table drive, re-engage the dividing head worm and perform the operation by hand turning of the crank, as already described.

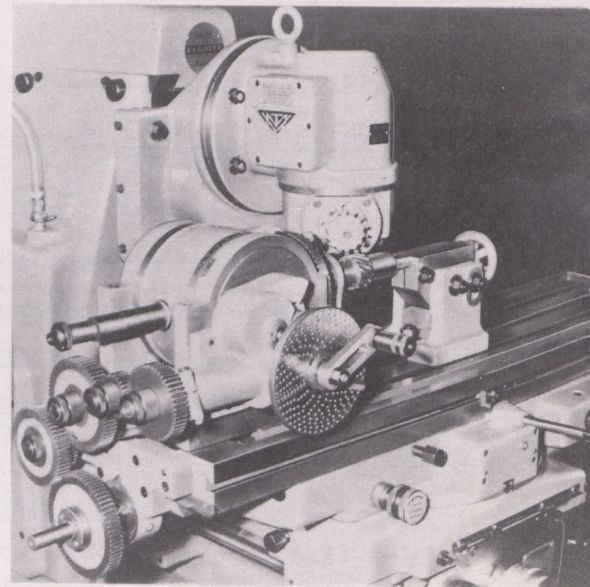

FIGURE 4

CUTTING HELICES. For spiral milling the hole plate is geared to the end of the table screw as already described. Thus with the locating plunger engaging any hole the crank must transmit the motion to the work spindle whilst the table travels. At the end of a cut the table is returned to the starting position, and the machine stopped so that the plunger can be moved as required to index the work.

All standard universal milling machines of British or American manufacture are fitted with a $\frac{1}{4}$ in. lead table guide screw. Since standard dividing heads contain a 40:1 reduction gear, it follows that with equal change gear ratio between head and table screw one revolution of the chuck will require 40 revolutions of the screw, which gives the Standard Lead of 10 in. Metric machines have a 5 mm pitch table screw giving a standard lead of 200 mm.

CALCULATION OF CHANGE GEARS. The determination of change gears for cutting leads, which are in whole numbers and simple fractions of inches, when cutting flutes in drills, etc. is easily accomplished. To cut a lead of $5\frac{1}{4}$ in.

$$\frac{\text{Lead required}}{\text{Standard Lead}} = \frac{5\frac{1}{4} \text{ in.}}{10 \text{ in.}} = \frac{21}{40}$$

$$= \frac{7 \times 3}{2 \times 2 \times 2 \times 5} = \frac{7}{8} \times \frac{3}{5}$$

It is obvious that the standard change gears $\frac{56}{64} \times \frac{24}{40}$

would give the required ratio though this gear train could not be set up for a right-hand helix, which requires no idlers, because the 64 tooth gear mounted with the 24 tooth gear on the stud would foul either the nut, or spacing collar adjacent to the final 40 tooth gear. The same gears are therefore used in the order

$$\frac{24}{64} \times \frac{56}{40}$$

Any idler may be inserted in the train at a convenient point to reverse the rotation of the work spindle for left hand helices.

In practice all the leads obtainable with the change gears supplied are listed in ascending order on pages 8 to 13 and for most purposes it is sufficient to select the lead which is nearest to what is desired. Where a more accurate result is essential, a calculation as per the foregoing example should be made so as to establish whether a mathematically exact solution can be found simply by producing one or more special change gears. If this procedure still does not result in a satisfactory solution, a computation based on continued fractions should be made, this as described on Page 24.

The table slide is swivelled clockwise for left hand helices and counter-clockwise for right hand helices by an amount equal to the spiral angle of the helix. When the spiral angle exceeds 30° the set-up becomes rather unsatisfactory on account of the excessive swivel of the table slide, and it is better to use a universal attachment so that the cutter spindle can be set to the required spiral angle and the table remain in the normal position. When the spiral angle exceeds 45° it is usually impossible to mill except by this method. (Fig.4)

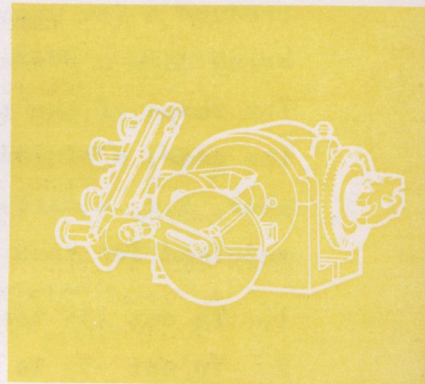

Non standard Leads. In the event of a close approximation being essential this can be done by resorting to continued fractions.

Ratio required in example = 27.557 : 10,000

$$\begin{array}{r}
 10,000 \overline{) 27,557} (2 \\
 \underline{20,000} \\
 7,557 \overline{) 10,000} (1 \\
 \underline{7,557} \\
 2,443 \overline{) 7,557} (3 \\
 \underline{7,329} \\
 228 \overline{) 2,443} (10 \\
 \underline{2,280} \\
 163 \overline{) 228} (1 \\
 \underline{163} \\
 65 \overline{) 163} (2 \\
 \underline{130} \\
 33, \text{ etc.}
 \end{array}$$

$$\frac{1}{0} \quad \frac{2}{1} \quad \frac{1}{1} \quad \frac{3}{4} \quad \frac{10}{41} \quad \frac{1}{45} \quad \frac{2}{131}, \text{ etc.}$$

Taking the ratio $\frac{124}{45}$ we get $\frac{124}{45} \times 10 \text{ in.} = 27.5555 \text{ in. lead}$

representing an error of only 0.0015 in. in 27.557 in. which is entirely negligible, but to do this special change gears would be required.

$$\frac{124}{45} = \frac{31 \times 2 \times 2}{5 \times 3 \times 3} = \frac{31}{5} \times \frac{4}{9} = \frac{62}{40} \times \frac{64}{36}$$

The 40 tooth and 64 tooth gears are standard, but those containing 62 and 36 teeth would have to be made for the purpose.

To perform the above calculation, first express the lead required divided by standard lead as a vulgar fraction, viz. 27,557/10,000. Then divide the denominator into the numerator, the quotient being 2 and the remainder 7557. Now divide the remainder into the divisor of the previous division and continue the process ad lib.

Arrange the quotients as shown and beneath the first one write down that quotient divided by one. In front of this fraction write $\frac{1}{0}$ and develop the succeeding fractions in the following manner.

To determine the numerator of the fraction beneath the second quotient multiply the latter by the numerator of the preceding fraction and add to the product the next preceding numerator. To determine the denominator of the fraction beneath the second quotient multiply the latter by the denominator of the preceding fraction and add to the product the next preceding denominator (which in the first stage is zero). For instance, to find the fraction beneath the fourth quotient:

$$\begin{array}{rcl}
 \text{Quotient x previous numerator} & = & 10 \times 11 \\
 \text{Add the next previous numerator} & & \\
 \text{and } (10 \times 11) + 3 & = & 113 \\
 \text{Quotient x previous denominator} & = & 10 \times 4 \\
 \text{Add the next previous denominator} & & \\
 \text{and } (10 \times 4) + 1 & = & 41
 \end{array}$$

$$\text{The fraction is } \frac{113}{41}$$

The process is continued in the same manner to obtain further fractions. It will be seen that each succeeding fraction represents a closer approximation to the required lead than the previous one, and it only remains to choose a sufficiently accurate fraction which will factorize suitably.

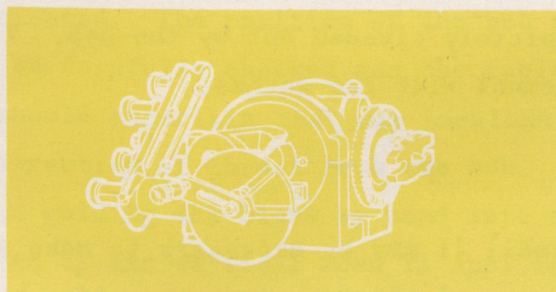

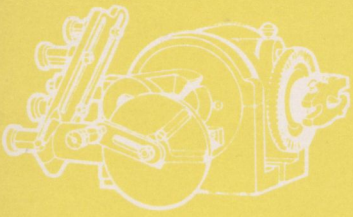

WORM GEARS. Worm wheels may be milled with great accuracy (Fig.5), and the method used is now being adopted for finishing worm gears which have been hobbed in the usual manner. To produce them on the miller a hob should be made which, before gashing, has a form identical with that of the worm, except that the outside diameter is increased to cut the clearance at the root of the wheel teeth. The gashes should be of a pitch fine enough to ensure that the hob can drive the worm wheel. It may fit on the arbor in the usual way, may be made solid to suit the spindle nose (or morse adaptor in case of International Standard spindle noses) and arbor steady, or may be overhung from the spindle nose, according to the diameter of the worm.

The wheel blank is set up between the dividing head and tailstock, and positively located with the former for indexing. The machine table is swivelled and set at an angle equal to the lead angle of the mating worm, the direction of swivel being determined by the hand of the latter. A roughing cutter, which may be a standard involute cutter but should preferably be smaller than the hob diameter and which represents a pitch not exceeding that to be cut, is mounted on the machine arbor, the wheel blank being centred beneath it. A number of gashes, corresponding to the number of teeth required in the worm wheel, are now cut to a depth which must be left to the discretion of the operator. The gashes should be deep enough to enable the hob to drive the wheel but no deeper, since they must subsequently be completely cleaned out by the hob. The best way is to try the hob by hand in engagement with the gashes.

Where the worm is very small it may be necessary to make a small gashing cutter similar to a woodruff or tee slotting cutter, the sides being tapered according to the pressure angle of the gears.

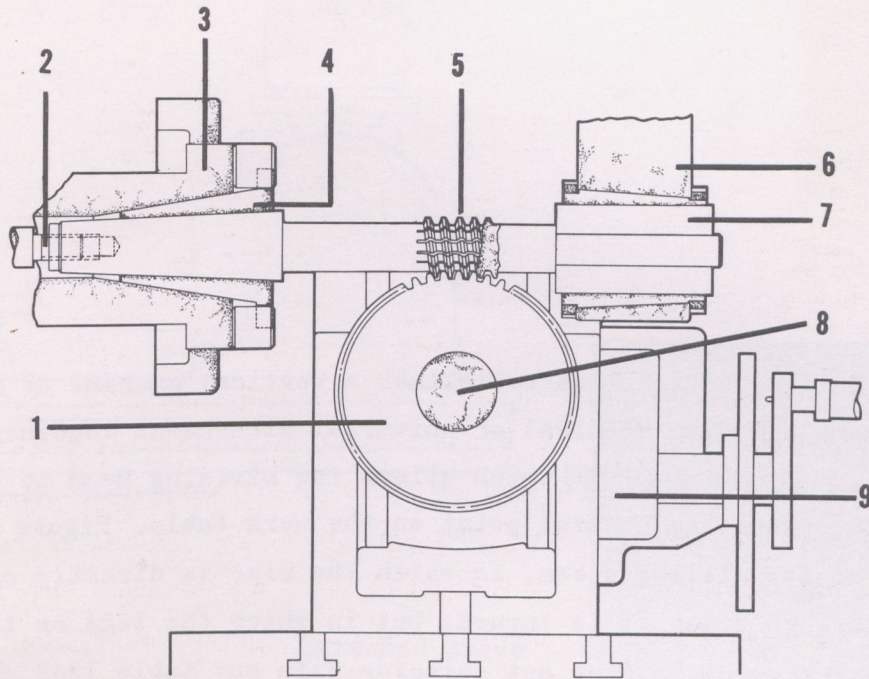

1	Workpiece	6	Machine Arbor Steady
2	Drawbar	7	Bearing pressed on to Hob
3	Machine Spindle	8	Mandrel
4	Morse Adaptor	9	Dividing Head
5	Hob		

FIGURE 5

When the gashes are completed the hob should be mounted on the spindle, the swivel slide brought back to the zero position, and the carrier removed so that the blank and its mandrel can rotate freely between the centres, which must now be suitably lubricated. The position of the hob relative to the boss face of the blank should be carefully checked and the table locked, or, failing that, the operator should ascertain that any backlash in the screw is taken up relative to the direction of thrust from the hob. The hob is engaged by raising the table and guiding the blank by hand into engagement, after which the spindle is started up and vertical feed is applied. A refinement which is worth adopting consists of moving the cross slide slightly towards and away from the column whilst the final sizing is done, thus overcoming the condition whereby a particular hob tooth always engages a particular wheel tooth at the same point in the cycle.

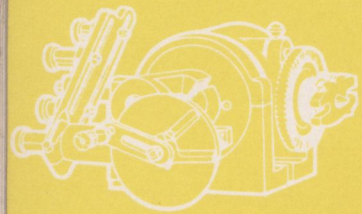

CAM MILLING. This operation requires either a vertical machine or a horizontal model complete with vertical or universal attachment together with an extended drive (Fig.6 Page 29) which allows the Dividing Head to be positioned at a reasonably central point on the work table. Figure 7 (Page 29) shows the set-up for milling a cam, in which the rise is directly proportional to the angle through which it is turned, but in which the lead or total rise for one complete revolution does not coincide with any table lead obtainable by using standard change wheels. The procedure is to select a standard table lead somewhat greater than the lead of the cam, and to set over both the dividing head spindle and the axis of the cutter to such an angle that the radial component of the table lead, or, in other words, the increment in the centre distance between the cutter and the work for a complete revolution of the latter, corresponds to the required cam lead. The diagram (Fig. 8 Page 29) shows that

$$\text{this angle is determined by } \cos. \alpha = \frac{\text{Lead of Cam}}{\text{Lead of Table}}$$

If the contour of the cam is to change its lead at certain points the table lead selected should be great enough to exceed the maximum cam lead, so that the various leads can be correctly generated by changing the angle of inclination but without changing the gears.

The cutter should, in general, be the same diameter as the roller which is to engage the cam. It should preferably have left hand helical flutes for right hand cutting and vice versa so as to thrust towards the spindle nose, and the length of the flutes must be sufficient to allow for the relative endwise movement of the work as indicated by X in the diagram.

Extended drive
Left hand
Dividing Head

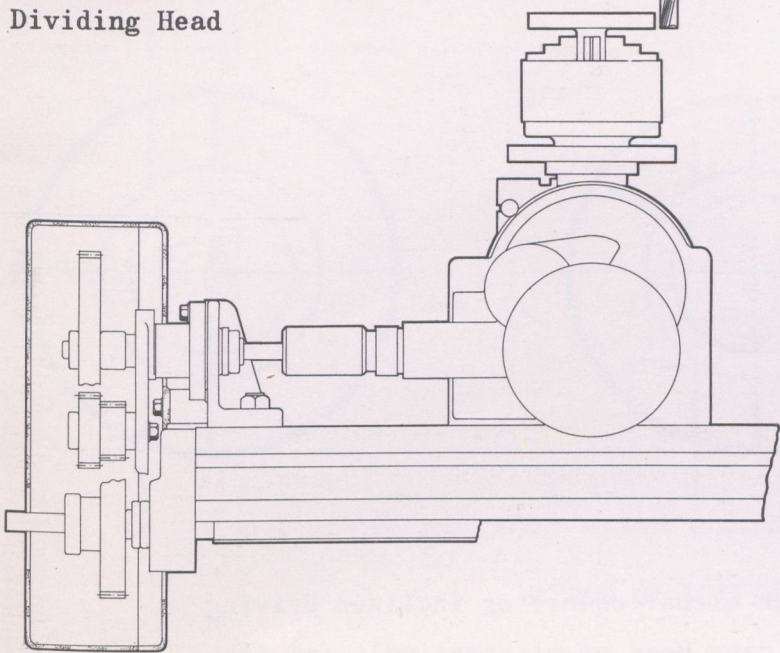

Extended drive
Right hand
Dividing Head

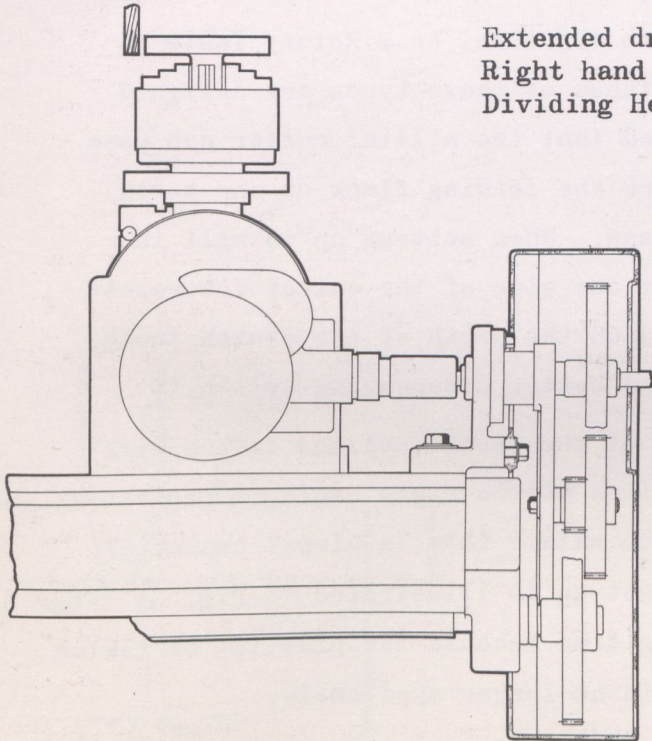

FIGURE 6

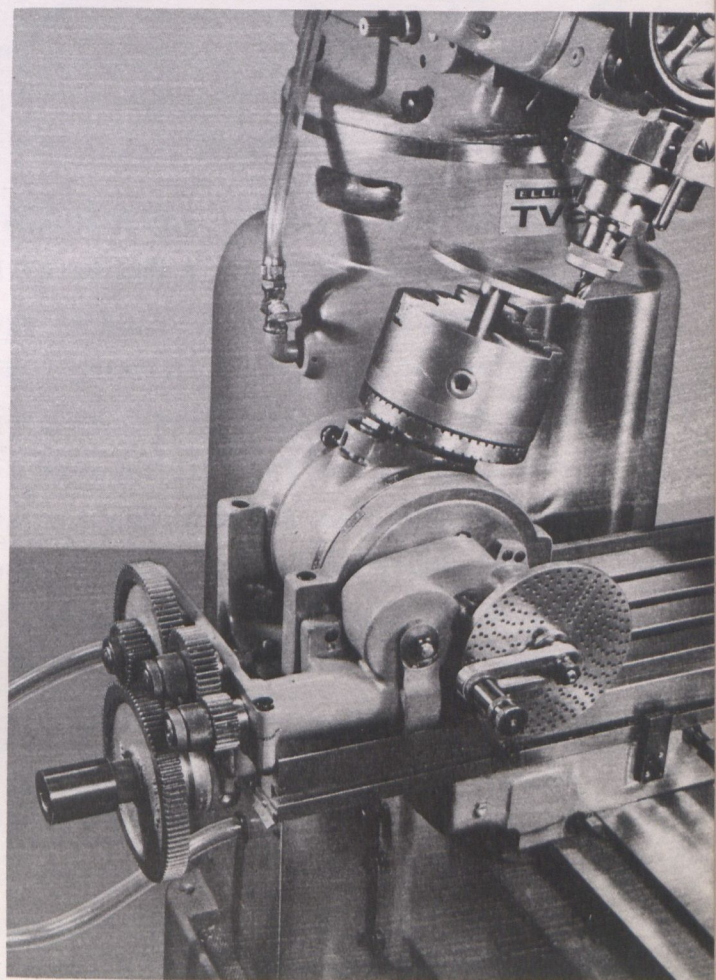
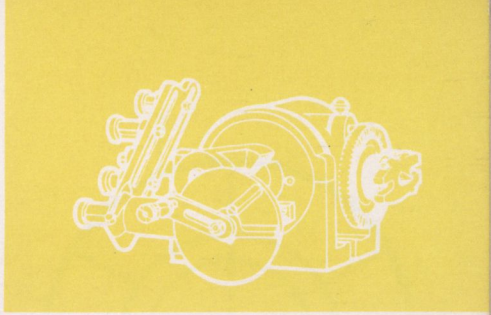

FIGURE 7

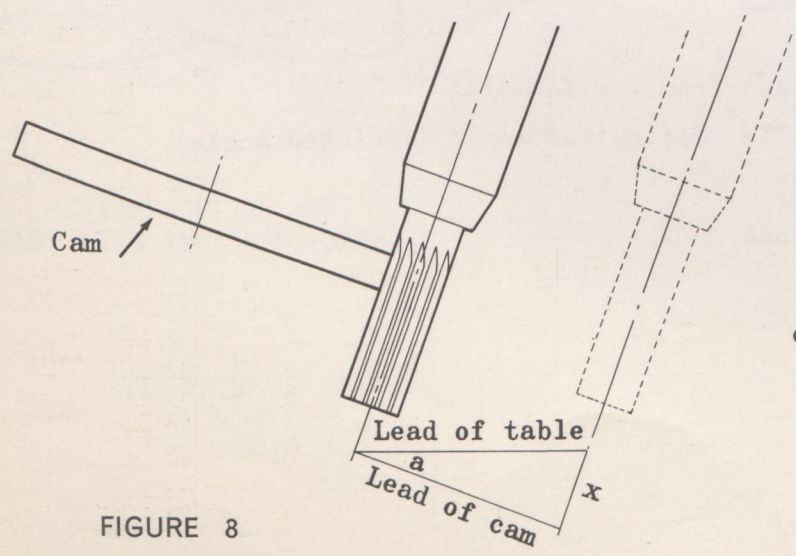
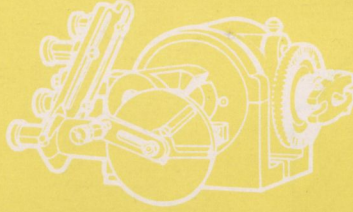

FIGURE 8

$$\cos.a = \frac{\text{Lead of cam}}{\text{Lead of table}}$$

$$x = \text{lead of table} \times \sin a$$



MILLING CLUTCH TEETH. Dog clutches with either square or inclined driving faces can be milled on a Universal Dividing Head or alternatively, if the root area of the spaces is to be square with the bore, on a Rotary Table provided with means of indexing. Most clutches of these types are designed with an odd number of teeth, so proportioned that the milling cutter can pass right across the face of the work to produce the leading flank on one tooth and the trailing flank of another at one pass. When setting up to mill inclined faces it is important to ensure that one side of the cutter intersects the axis of the clutch at a point halfway down the depth of the clutch tooth. All clutches with inclined teeth will have a better disengaging action if they are designed to be cut with the roots of the teeth inclined to the axis so that when pairs are fully engaged the lines of the roots could be projected to meet at a common apex point on the clutch axis. This is almost essential in the case of vee tooth clutches and the set-up is illustrated in Fig. 11 (Page 31) This technique however, increases machining time because the practice of taking the pass right across the clutch diameter is no longer applicable.

The angle θ is determined from the formula:

$$\cos \theta = \tan \frac{180^\circ}{N} \times \cot \text{cutter angle (included angle)}$$

where

$$N = \text{No. of teeth.}$$

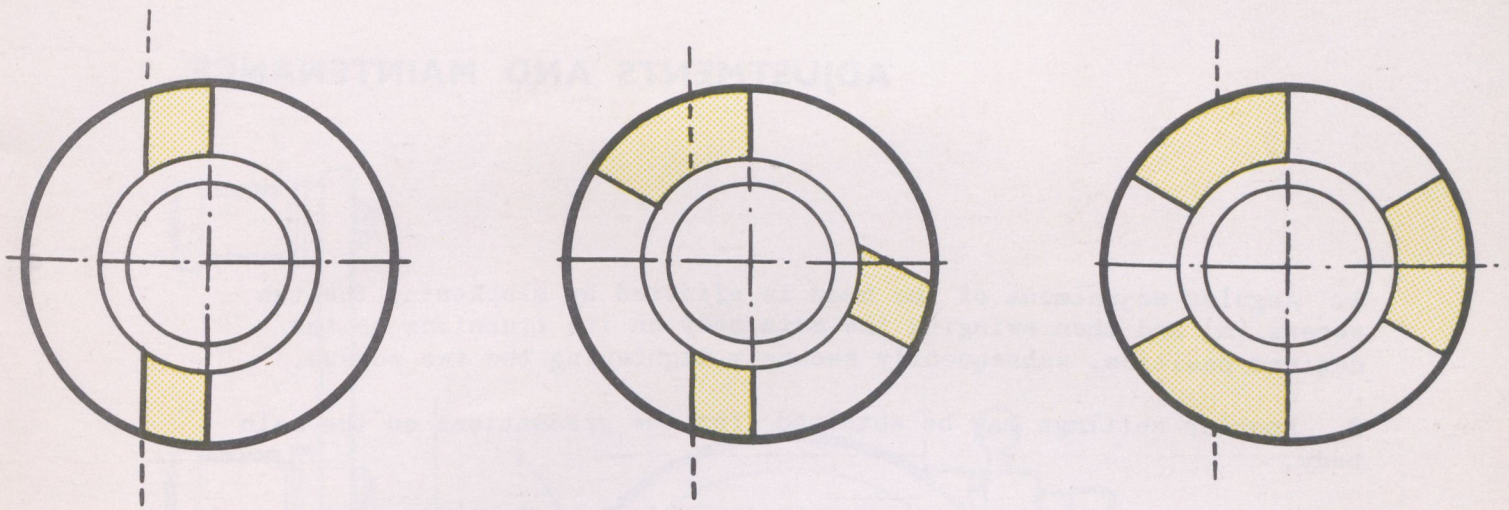

METHOD OF CUTTING CLUTCH TEETH

FIGURE 9

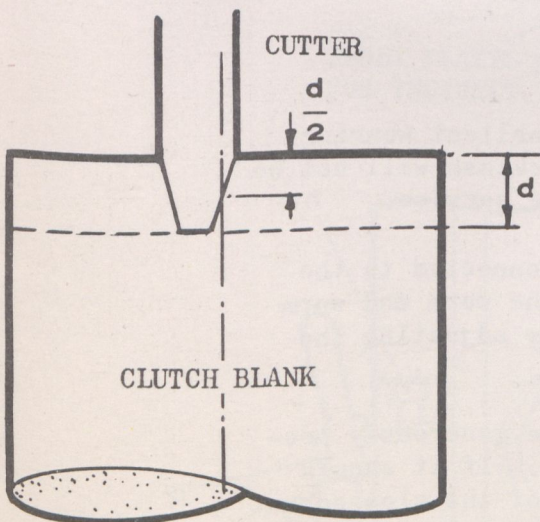

SETTING CUTTER FOR
TEETH WITH INCLINED FACES

FIGURE 10

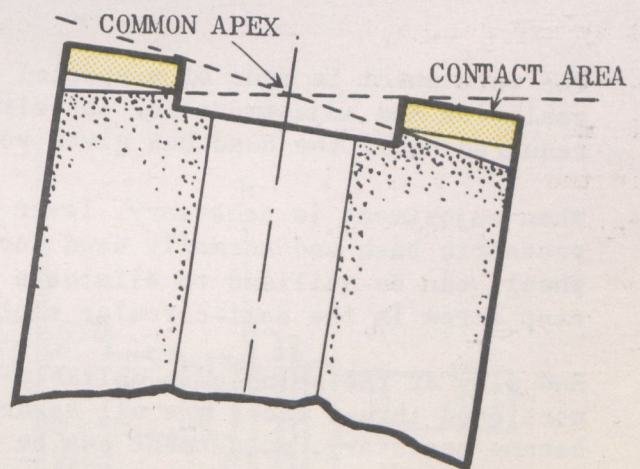

INCLINED ROOTS FOR
BETTER DISENGAGING ACTION

FIGURE 11

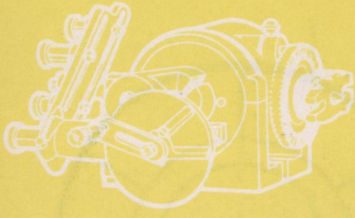

ADJUSTMENTS AND MAINTENANCE

1. Angular adjustment of the head is effected by slackening the two screws (m) and then swinging the main body on its trunnions to the desired position, subsequently securely tightening the two screws.
2. Angular settings may be obtained from the graduations on the main body.
3. When the head has been used with the spindle axis inclined it should be reset in the horizontal position by clocking a test bar held in the spindle taper.
4. Chuck adaptors and other work holders should be located on the outside diameter of the spindle nose which is threaded to enable these to be screwed to the spindle.
5. For differential indexing it is necessary to fit the differential shaft (i) by inserting the expanding spigot into the rear of the spindle and securing by tightening the nut (o).
6. The clamp lever (p) at the back of the dividing head, remote from the operator, serves to lock the main spindle after indexing and should be used whenever cutting is performed with the spindle stationary.

The worm wheel is made of a special bronze with excellent wearing qualities and adjustment for the elimination of backlash will not be required until the head has given very considerable service.

When adjustment is necessary, lever (a) which is connected to the eccentric bush and normally used for disengaging the worm and worm wheel, can be utilised to eliminate any backlash by adjusting the stop screw in the semi-circular slot.

End play of the spindle is unlikely to arise as the generously proportioned thrust faces are all hardened and ground. If it should become necessary, adjustment can be made by means of the slotted nut immediately behind the worm wheel. This nut is revealed after removing the name plate on the head, and can be tightened after releasing the grub screw securing it to the spindle. After adjustment the grub screw should be re-tightened and the safety clip replaced.

Internal lubrication is provided by an oil bath. The oil should be changed annually, draining and re-filling through the access hole covered by the name plate.

A lubricating nipple is provided for the main spindle bearing and oil holes for the rear spindle bearing, for the spiral gear drive and for replenishing the reservoir. These should receive attention at least once per day when the head is in continuous use.

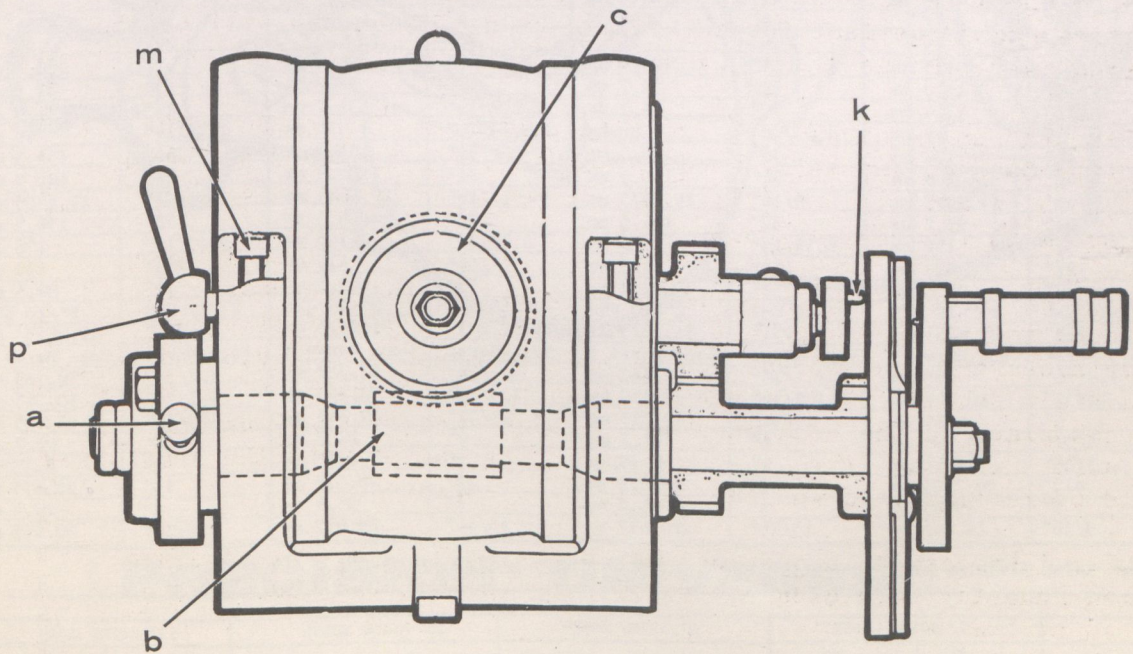
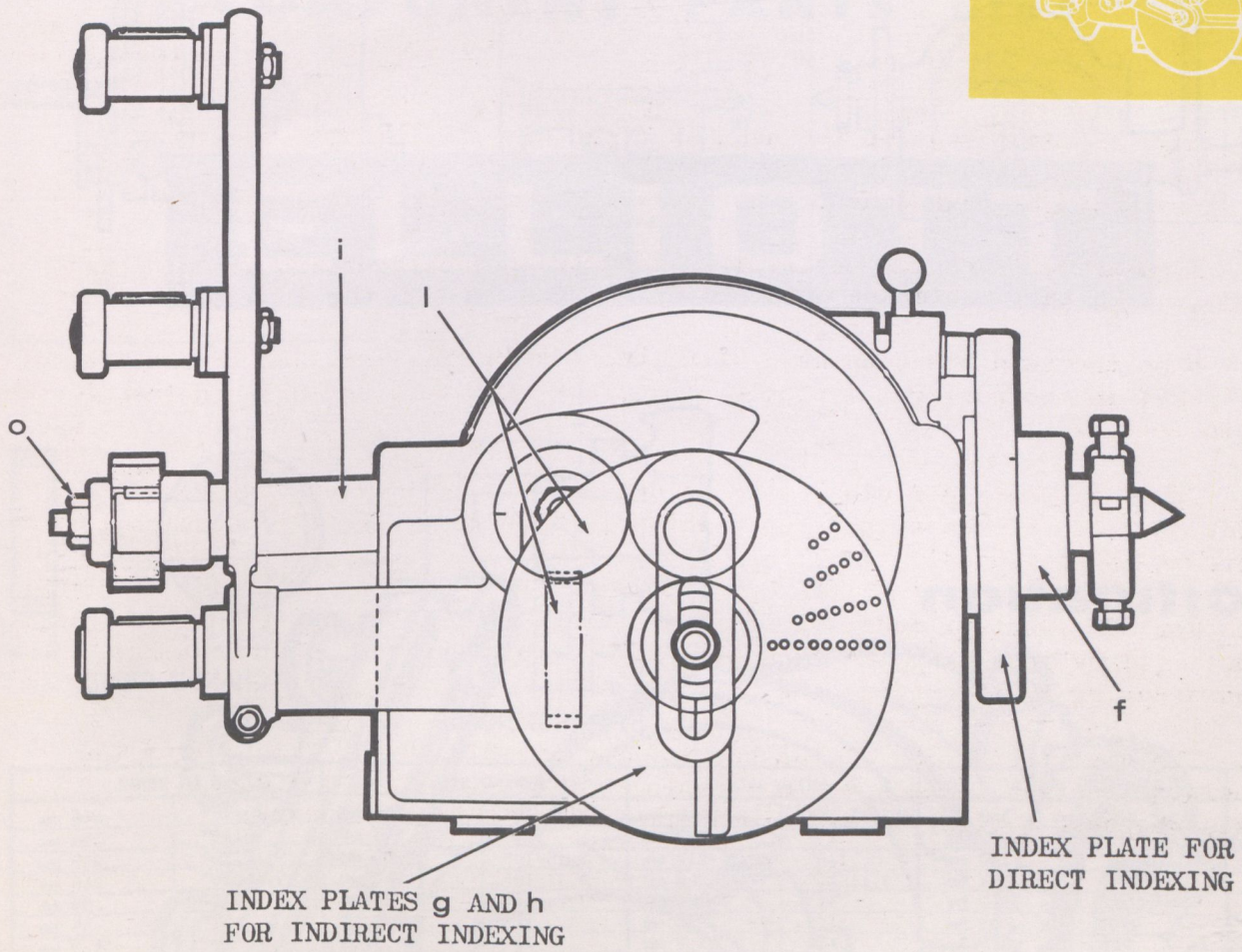
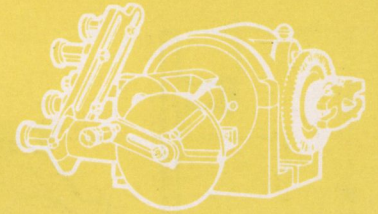
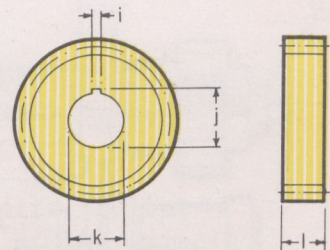
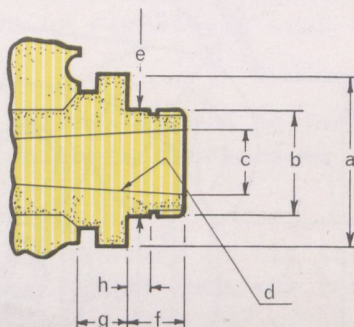
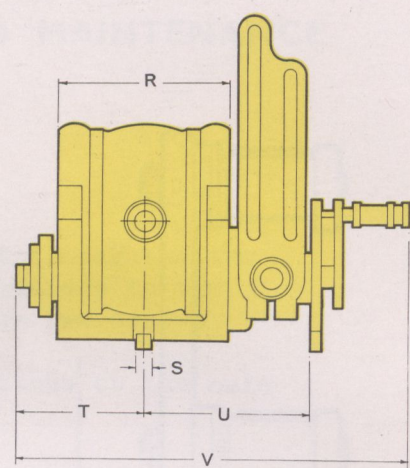
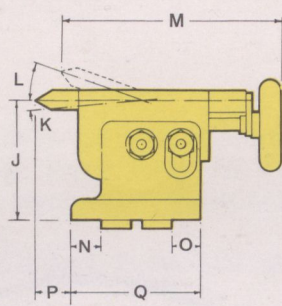
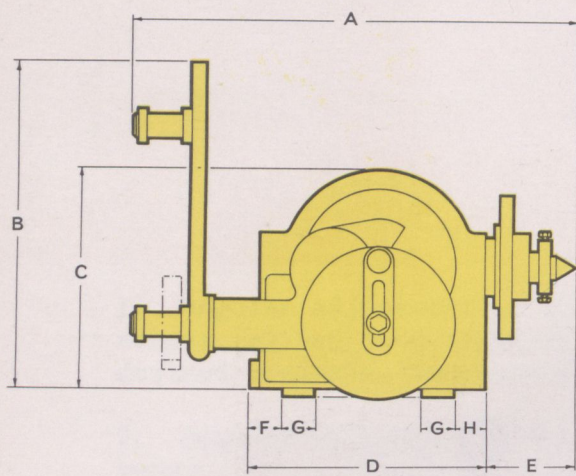

FIGURE 12



specification

SPINDLE NOSE

CHANGE GEARS

	7" SWING MODEL		9" SWING MODEL		10" SWING MODEL		12" SWING MODEL	
A	12 $\frac{1}{8}$ "	308 mm	17.15/16"	456 mm	17.15/16"	456 mm	17.15/16"	456 mm
B	8 $\frac{3}{4}$ "	222 mm	13"	330 mm	13 $\frac{1}{2}$ "	343 mm	14 $\frac{1}{2}$ "	368 mm
C	6.5/16"	160 mm	8.7/16"	214 mm	8.15/16"	227 mm	9.15/16"	252 mm
D	7 $\frac{1}{4}$ "	184 mm	9.11/16"	246 mm	9.11/16"	246 mm	9.11/16"	246 mm
E	1 $\frac{1}{4}$ "	31.7 mm	5 $\frac{3}{8}$ "	89 mm	5 $\frac{3}{8}$ "	89 mm	5 $\frac{3}{8}$ "	89 mm
F	1 $\frac{3}{8}$ "	35 mm	1 $\frac{3}{8}$ "	35 mm	1 $\frac{3}{8}$ "	35 mm	1 $\frac{3}{8}$ "	35 mm
G	1 $\frac{1}{8}$ "	28.5 mm	1 $\frac{1}{4}$ "	31.7 mm	1 $\frac{1}{4}$ "	31.7 mm	1 $\frac{1}{4}$ "	31.7 mm
H	1.5/16"	33.3 mm	1 $\frac{1}{8}$ "	35 mm	1 $\frac{1}{8}$ "	35 mm	1 $\frac{1}{8}$ "	35 mm
J	3 $\frac{1}{2}$ "	89 mm	4 $\frac{1}{2}$ "	114 mm	5"	127 mm	6"	152 mm
K	14 $\frac{0}{32}$ "	14 $\frac{0}{32}$ "	4 $\frac{0}{32}$ "	4 $\frac{0}{32}$ "	4 $\frac{0}{32}$ "	4 $\frac{0}{32}$ "	4 $\frac{0}{32}$ "	4 $\frac{0}{32}$ "
L	14 $\frac{0}{32}$ "	14 $\frac{0}{32}$ "	20 $\frac{0}{32}$ "	20 $\frac{0}{32}$ "	20 $\frac{0}{32}$ "	20 $\frac{0}{32}$ "	20 $\frac{0}{32}$ "	20 $\frac{0}{32}$ "
M	6 $\frac{1}{8}$ "	155.5 mm	9"	228.6 mm	9"	228.6 mm	9"	228.6 mm
N	1 $\frac{1}{8}$ "	15.8 mm	1 $\frac{1}{4}$ "	31.7 mm	1 $\frac{1}{4}$ "	31.7 mm	1 $\frac{1}{4}$ "	31.7 mm
O	11/16"	17.4 mm	1 $\frac{1}{4}$ "	31.7 mm	1 $\frac{1}{4}$ "	31.7 mm	1 $\frac{1}{4}$ "	31.7 mm
P max	3 $\frac{3}{4}$ "	19 mm	1.13/16"	46 mm	1.13/16"	46 mm	1.13/16"	46 mm
Q	4 $\frac{1}{4}$ "	108 mm	5 $\frac{1}{4}$ "	133.3 mm	5 $\frac{1}{4}$ "	133.3 mm	5 $\frac{1}{4}$ "	133.3 mm
R	4 $\frac{3}{8}$ "	123.8 mm	7 $\frac{1}{8}$ "	180.9 mm	7 $\frac{1}{8}$ "	180.9 mm	7 $\frac{1}{8}$ "	180.9 mm
S	9/16"	14.2875 mm	9/16"	14.2875 mm	11/16"	17.4625 mm	11/16"	17.4625 mm *
T	3 $\frac{3}{4}$ "	95.2 mm	5 $\frac{3}{8}$ "	136.5 mm	5 $\frac{3}{8}$ "	136.5 mm	5 $\frac{3}{8}$ "	136.5 mm
U	5 $\frac{1}{8}$ "	130 mm	6.15/16"	176 mm	6.15/16"	176 mm	6.15/16"	176 mm
V	12 $\frac{3}{4}$ "	324 mm	16 $\frac{1}{2}$ "	419 mm	16 $\frac{1}{2}$ "	419 mm	16 $\frac{1}{2}$ "	419 mm
a dia	2"	50.8 mm	2 $\frac{1}{4}$ "	82.5 mm	2 $\frac{1}{4}$ "	82.5 mm	2 $\frac{1}{4}$ "	82.5 mm
b	1 $\frac{1}{2}$ "-10 UNS	1 $\frac{1}{2}$ "-10 UNS	2"-10 UNS	2"-10 UNS	2"-10 UNS	2"-10 UNS	2"-10 UNS	2"-10 UNS
c dia	.938"	23.8251 mm	1.231"	31.2673 mm	1.231"	31.2673 mm	1.231"	31.2673 mm
d taper	No. 3 Morse	Cone Morse 3	No. 4 Morse	Cone Morse 4	No. 4 Morse	Cone Morse 4	No. 4 Morse	Cone Morse 4
e dia	1.9/16"	39.688 mm	2.1/16"	52.388 mm	2.1/16"	52.388 mm	2.1/16"	52.388 mm
f	21/32"	16.668 mm	1.3/16"	30.163 mm	1.3/16"	30.163 mm	1.3/16"	30.163 mm
g	1/4"	6.35 mm	25/32"	19.843 mm	25/32"	19.843 mm	25/32"	19.843 mm
h	5/32"	3.968 mm	1/2"	12.7 mm	1/2"	12.7 mm	1/2"	12.7 mm
i	3/16"	4.762 mm	1/2"	6.35 mm	1/2"	6.35 mm	1/2"	6.35 mm
j	.815"	20.7009 mm	1 $\frac{1}{8}$ "	28.575 mm	1 $\frac{1}{8}$ "	28.575 mm	1 $\frac{1}{8}$ "	28.575 mm
k dia	3/4"	19.05 mm	1"	25.4 mm	1"	25.4 mm	1"	25.4 mm
l	9/16"	14.287 mm	13/16"	20.637 mm	13/16"	20.637 mm	13/16"	20.637 mm

* NOTE: FOR 12" SWING DIVIDING HEADS SUPPLIED WITH ELLIOTT 70 SERIES MILLS DIMENSION S = $\frac{11}{16}$ " (18 mm)

SPECIFICATION	7" SWING MODEL		9" SWING MODEL		10" SWING MODEL		12" SWING MODEL	
Height of centres	3 $\frac{1}{2}$ "	89 mm	4 $\frac{1}{2}$ "	114 mm	5"	127 mm	6"	152 mm
Worm gear ratio	1:40	1:40	1:40	1:40	1:40	1:40	1:40	1:40
Spindle bore	17/32"	13.5 mm	7/8"	22 mm	7/8"	22 mm	7/8"	22 mm
Taper of dividing head spindle	No. 3 Morse	Cone Morse 3	No. 4 Morse	Cone Morse 4	No. 4 Morse	Cone Morse 4	No. 4 Morse	Cone Morse 4
Code word	VICME	VICME	VININ	VININ	VITEN	VITEN	VIDOZ	VIDOZ

COMPONENT PARTS LIST

ELLIOTT

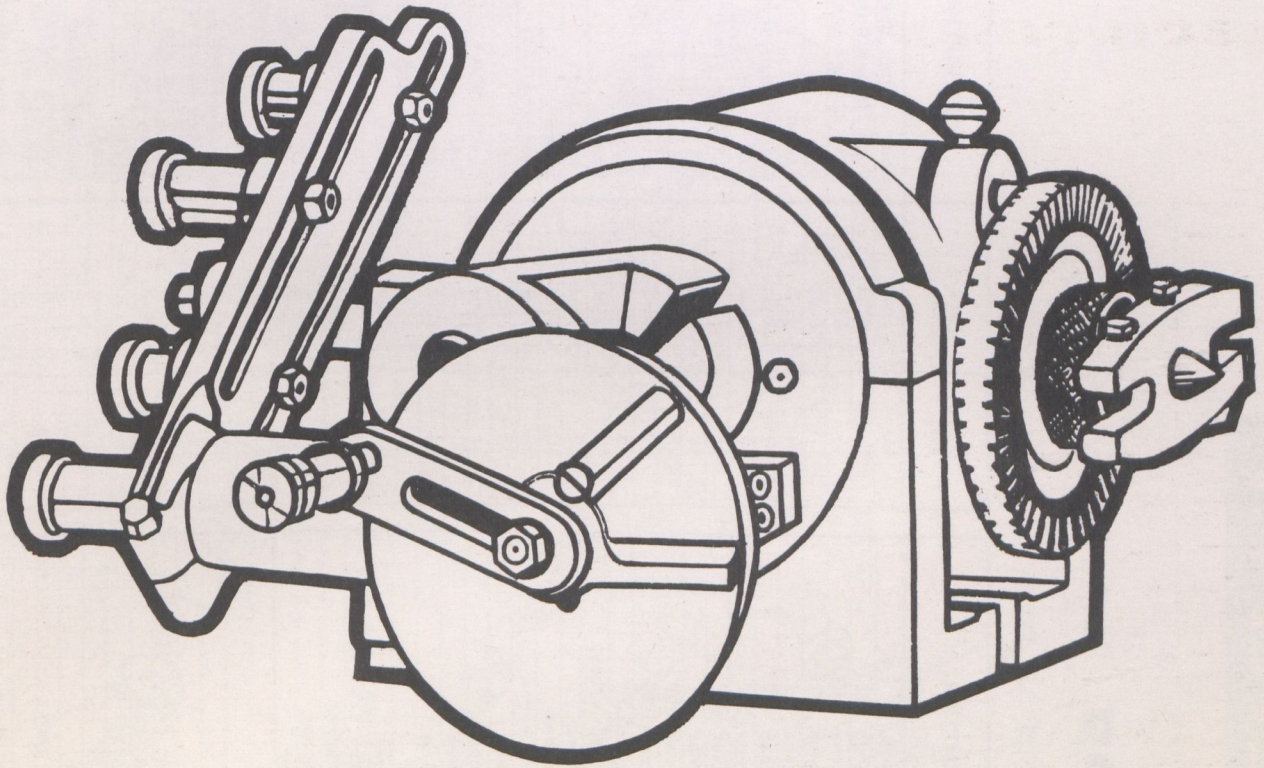

PRECISION UNIVERSAL

DIVIDING HEADS

7" swing

Illus. No.	Part No.	DESCRIPTION
1	5-27-A	Knurled nut
2	5-55-A	Change gear 24T
	5-56-A	Change gear 28T
	5-57-A	Change gear 32T
	5-58-B	Change gear 40T
	5-59-B	Change gear 48T
	5-60-B	Change gear 56T
	5-61-B	Change gear 64T
4	5-62-B	Change gear 72T
5	5-63-C	Change gear 86T
6	5-64-C	Change gear 100T
7	5-75-A	Retaining nut
8	5-26-B	Differential arbor
9	5-77-B	Long drawbar
10	5-78-B	Short drawbar
11	-	Socket cap screw
12	5-5-C	L.H Segment
13	5-4-C	R.H Segment
14	BSP. 12219	Slotted nut
15	5-39-A	Wormscrew
16	5-18-B	$\frac{1}{2}$ Wormwheel
17	5-17-B	$\frac{3}{4}$ Wormwheel with boss
18	5-25-B	Spacing washer
19	5-31-A	Thrust washer
20	5-68-A	Oil washer
21	BOP. 17920-B	Cover
22	1-53-A	Slot nut
23	5-8-A	Bush
24	5-9-B	Driver
25	8-12-A	No. 3 Morse taper centre
26	5-84-B	Protecting nut
27	5-83-C	Main spindle
28	K2066-B	Key
29	5-30-B	Wormshaft
30	5-21-A	Clamping pad
31	5-53-A	Screw
32	5-46-A	Eccentric screw
33	5-1-D	Body
	24-52-A	Handle
	5-22-A	Locking bolt
	-	Oiler

Illus. No.	Part No.	DESCRIPTION
34	5-10-B	Gear change bracket
35	5-42-A	Gear change spindle
36	5-43-A	Gear change sleeve
37	k00-07	Key
38	5-51-A	Washer
39	5-40-A	Gear change screw
40	1-40-A	Pin
41	5-37-A	Dividing plate lock
42	BOP. 269-A	Spring
43	5-49-A	Screw
44	5-38-B	Idler arbor
45	5-15-A	Idler 26T
46	5-48-A	Bush
47	5-50-A	Table bolt
48	1-44-A	Tenon
49	5-47-A	Clamping bolt
50	5-2-C	Base
51	5-44-A	Spiral pin
52	5-14-A	Bush
53	5-12-A	Spur gear 26T
54	5-11-A	Spiral gear with boss 19T
55	5-54-A	Screw
56	5-15-A	Spiral gear 19T
57	5-3-C	Gear bracket
58	5-45-A	Clamp block
59	5-16-B	Plate gear 26T
60	5-6-A	Eccentric sleeve
61	K12-03	Key
62	5-41-B	Spiral arbor
63	5-20-A	Bottom index arm
64	5-19-A	Top index arm
65	5-34-A	Index pin
66	BOP. 100-A	Spring
67	5-72-A	Handle
68	5-73-A	Knurled collar
69	5-71-A	Indexing barrel
70	5-74-A	Indexing arm
71	BOP. 99-A	Index and spring
72	5-32-A	Screw
73	5-52-A	Countersunk screw
74	5-33-B	Index plate 'A'
	5-67-B	Index plate 'B'

WORK SUPPORT JACK

Illus. No.	Part No.	DESCRIPTION
1	7-3-A	Adjusting screw
2	7-2-A	Adjusting nut
3	7-1-A	Body
4	7-4-A	Thump screw
5	5-50-A	Table bolt

TAILSTOCK

Illus. No.	Part No.	DESCRIPTION
1	2-7-A	Centre
2	6-2-B	Footstock body
3	6-6-A	Short clamping bolt
4	6-7-A	Long clamping bolt
5	6-9-A	Link bolt
6	6-8-A	Feed screw
7	6-4-A	Centre sleeve
8	6-5-A	Link
9	6-3-A	Handwheel
10	1-44	Tenon
11	5-50-A	Table bolt
12	6-1-C	Footstock base

Items 27, 31 and 32 only fitted when specially ordered.

7" swing

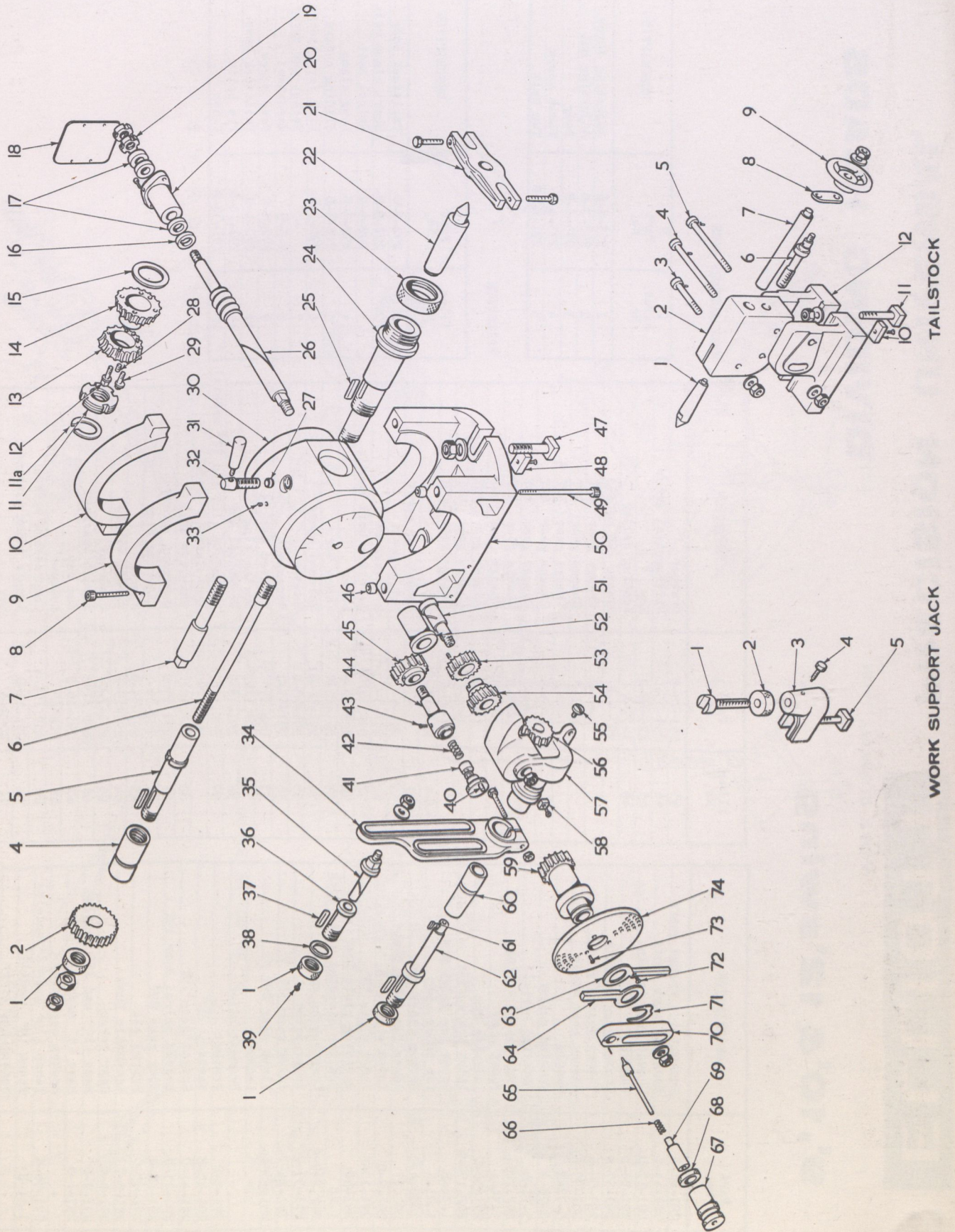

9", 10" & 12" swing

Illus. No.	Part No.	DESCRIPTION
1	291-26-B	Locknut for change gears
2	291-44-C	Backgear stub shaft
3	291-17-D	Change gear bracket
4	291-54-B	Washer
5	291-57-B	Change gear spindle
6	291-58-B	Change gear sleeve
7	291-59-B	Change gear screw
8	5-72-A	Handle
9	5-73-A	Knurled collar
10	5-71-A	Indexing barrel
11	BOP.100	Compression spring
12	5-34-A	Index pin
13	291-36-C	Indexing arm
14	BOP.190-B	Index arm spring
15	1-34-B	Screw for index arm
16	1-21-A	Top index arm
17	1-22-A	Bottom index arm
18	291-37	Screw for index plate
19	291-9-C	Index plate 'A'
20	291-10-C	Index plate 'B'
20A	291-40	Dividing plate lock
21	1-40	Pin for dividing plate lock
22	BOP.269-A	Compression spring
23	291-39-C	Idler arbor
24	291-14-B	Idler gear 31T
25	291-13-B	Plate gear 29T
26	-	Locknut
27	-	Bennett oiler
28	291-5-D	Bracket
29	291-45-B	Washer
30	291-41-B	Spiral gear 19T
31	291-15-B	Bossed spiral gear 19T
32	291-12-B	Spur gear 29T
33	291-43-C	Spiral pin
34	291-8-D	Eccentric bush
35	291-6-C	Gear cover
36	291-2-D	Base (10" and 12" models)
37	297-1-D	Base (9" model)
38	-	Socket cap screw
39	291-56-B	Tenon (10" and 12" models)
40	1-44-B	Tenon (9" model)
41	291-60-B	Socket cap screw
42	297-2-B	Tee bolt (10" and 12" models)
43	1-53-A	Bush for base
44	-	L2 Lubricator
45	291-1-E	Body

Illus. No.	Part No.	DESCRIPTION
43	291-28-B	Drawbar
44	291-25-C	Differential arbor
45	K20-68-B	Key
46	1-77-A	Spacing collar
	297-4-B	Spacer (9" model)
	1-60-B	Change gear 24T
	1-61-B	Change gear 28T
	1-62-B	Change gear 32T
	1-63-B	Change gear 40T
	1-64-B	Change gear 48T
	1-65-B	Change gear 56T
	1-66-B	Change gear 64T
	1-67-B	Change gear 72T
	1-68-C	Change gear 86T
	1-69-C	Change gear 100T
47	K14-10	Key
48	-	Socket cap screw
49	291-4-C	L.H. segment
50	291-5-C	R.H. segment
51	BOP.18103	Bakelite ball handle
52	291-30-B	Lever
52A	291-52-B	Clamp bar
53	291-51-B	Screwed piece
54	291-50-B	Handle
55	291-31-C	Wormshaft
56	USN 1 3/8"	Slotted nut
57	BOP.12228-B	Spring ring
58	291-18-B	Wormwheel 40T
59	BOP.17872-C	Nameplate (10" and 12" models)
60	BOP.17900-C	Nameplate (9" model)
61	BOP.18103	Bakelite ball
62	291-53-B	Quadrant lever
63	187-36-A	Clamping ring
64	291-34-B	Spacer
65	291-19-B	Thrust washer
66	291-7-C	Quadrant
67	BOP.2198	Thrust bearings
68	291-16-B	End cap
69	ULN 3/8"	Locknut
70	BOP.191-A	Compression spring
71	291-29-B	Simple index plunger
72	2092-B	Key
73	291-21-D	Main spindle
74	291-11-C	Index plate
75	291-27-B	Protecting nut
76	1-25-B	No. 4 Morse taper centre
	291-55-B	Driver

WORK SUPPORT JACK

Illus. No.	Part No.	DESCRIPTION
1	293-2-B	Adjusting screw
2	293-3-B	Adjusting nut
3	293-1-B	Body
4	293-4-B	Thumb screw
5	291-60-B	Tee bolt

TAILSTOCK

Illus. No.	Part No.	DESCRIPTION
1	292-2-C	Tailstock body
2	292-5-B	Short clamp bolt
3	292-4-B	Swivel bolt
4	292-6-B	Long clamp
5	292-3-B	Sliding centre
6	292-7-B	Link for sliding centre
7	-	Socket cap screw
8	2-3-B	Handwheel
9	292-8-B	Feed screw
10	292-1-D	Tailstock base
11	292-10-B	Tee bolts
12	291-56-B	Tenon

9", 10" & 12" swing

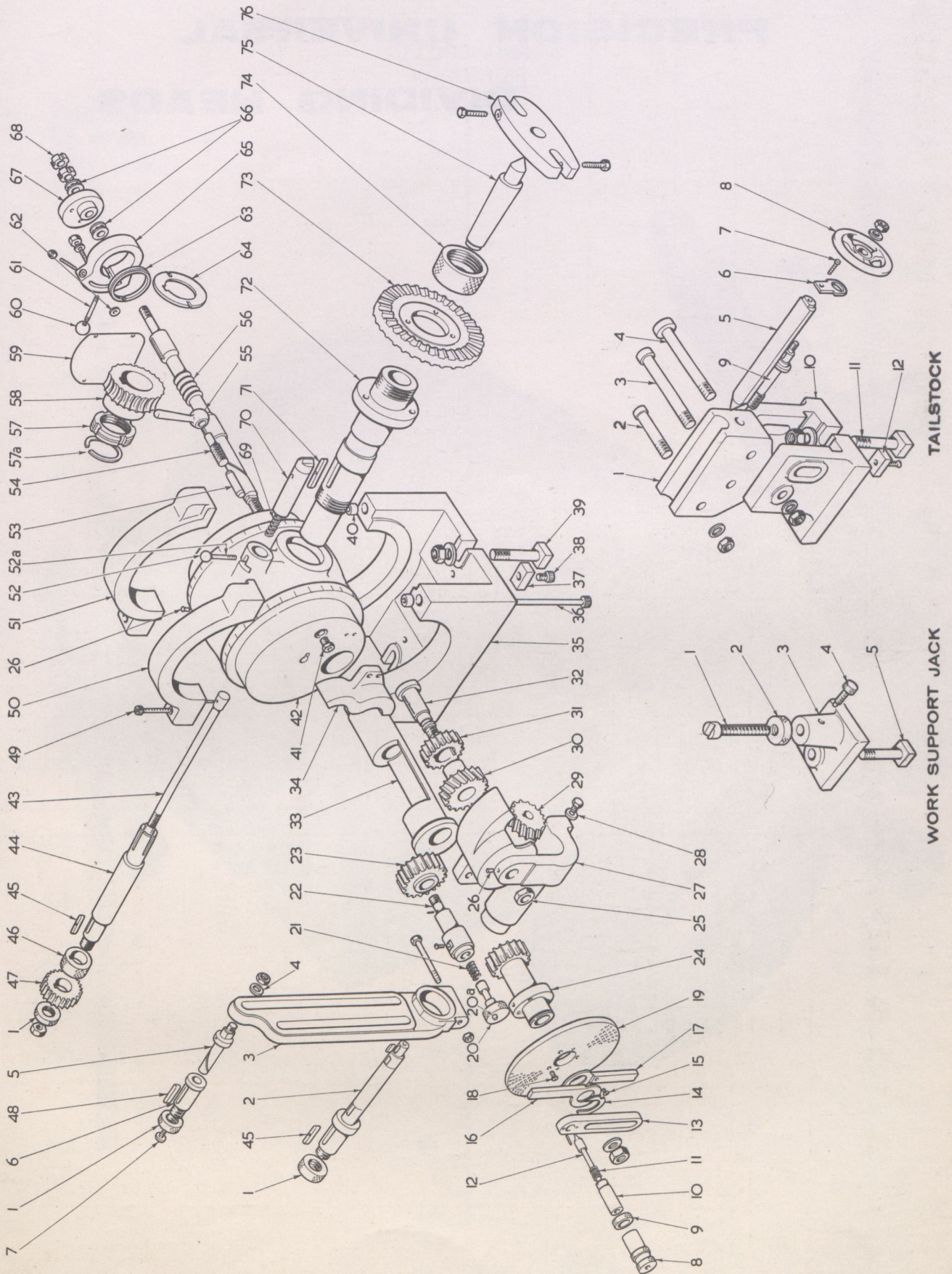

ELLIOTT

PRECISION UNIVERSAL

DIVIDING HEADS

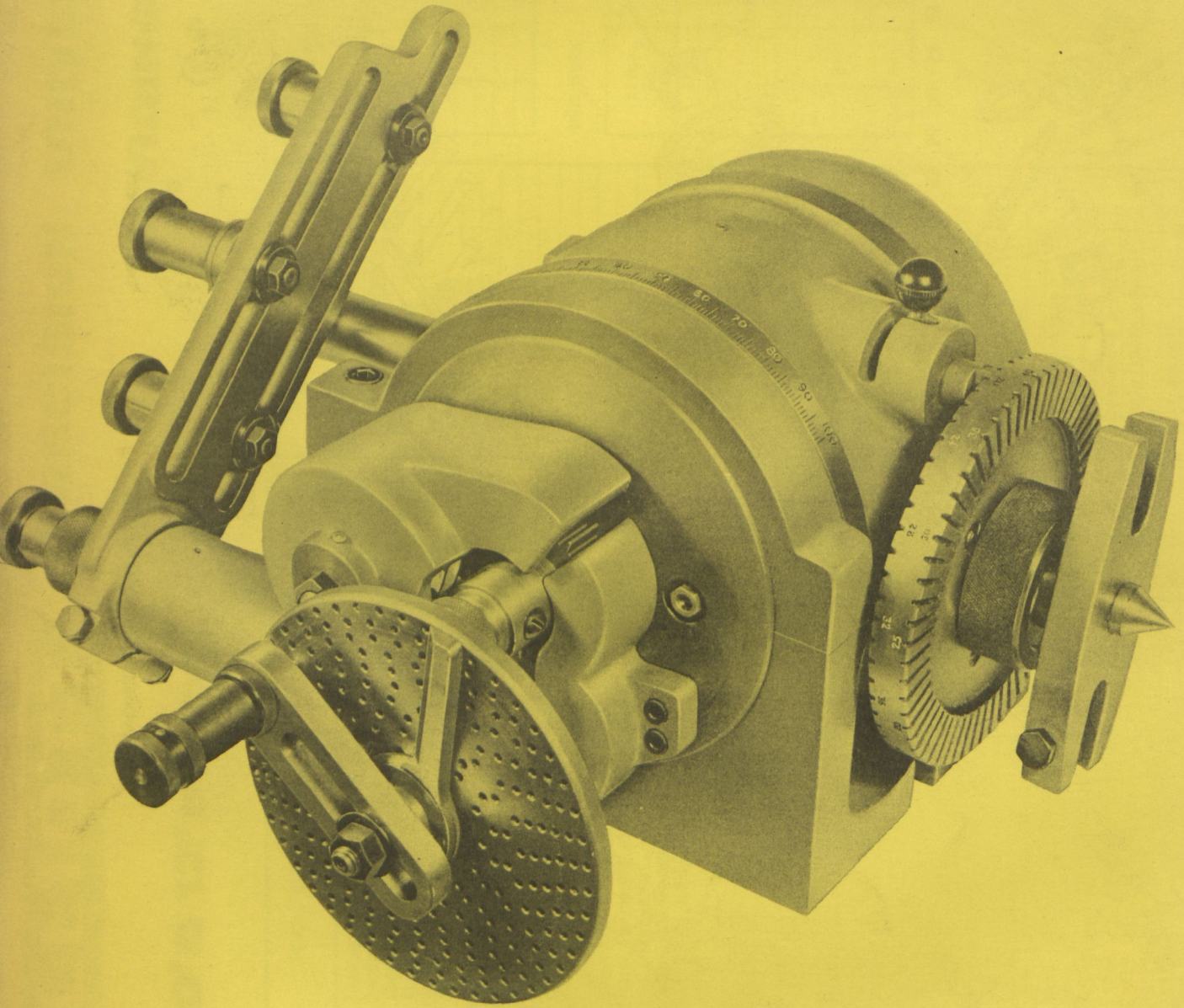

NOMOGRAPH TO GIVE ANGULAR SETTINGS FOR SPIRAL MILLING

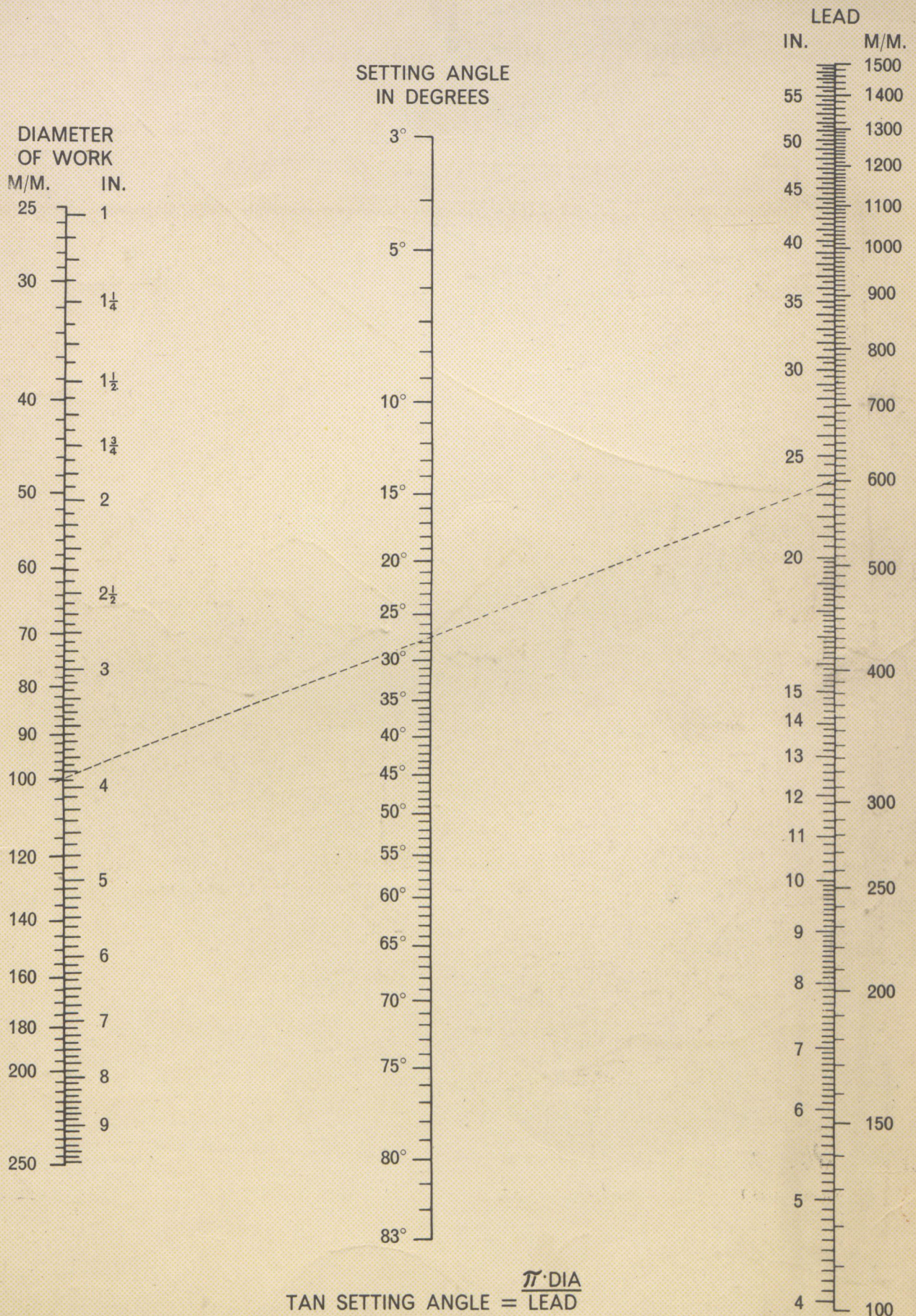

B. ELLIOTT (MACHINERY) LTD.

VICTORIA ROAD · LONDON · N.W.10

TELEPHONE: ELGAR 4050 (14 LINES)
TELEGRAMS: ELLIOTTONA, LONDON, N W 10

Overseas Subsidiaries: AUSTRALIA · CANADA · SOUTH AFRICA · USA · SOUTH AMERICA



Printed in England PD. 5 64