



Harrison M300

330 mm - 13 in swing

CENTRE
LATHE

600



Harrison M300

330 mm (13 in) swing CENTRE LATHE

MODEL M325 630 mm (25") between centres

MODEL M340 1000 mm (40") between centres

The Harrison M300 is a robust, versatile centre lathe which is equally suited to the demands of industry or vocational training requirements. Safety, reliability and simplicity of operation are principal characteristics, whilst an unrivalled range of accessories is offered.

Manufactured to British metric standards throughout, this machine is available in two bed lengths – each with either gap or straight bed versions.

A left or right hand apron handwheel is optional and metric or English drive screws (together with the appropriate micrometer dials) are supplied as standard.

summarised specification

safety features are highlighted thus ● in the text that follows.

| | | | | | |
|--------------|-----------------------------|--|------------------------|--------------------------------------|--|
| Centres | Height | 167 mm (6 $\frac{5}{16}$ ") | Feeds | 16 Metric (R.10 Series)..... | from .03 to 1 mm/rev. |
| | Admits between | 635 mm (25") | | 16 English | from .001 to .040"/rev. |
| | or..... | 1000 mm (40") | | Cross Feeds Half Longitudinal Values | |
| Swing | Over Bed | 330 mm (13") | Cross Slide | Width..... | 140 mm (5 $\frac{1}{2}$ ") |
| | Over Cross Slide | 210 mm (8 $\frac{1}{4}$ ") | | Travel | 190 mm (7 $\frac{1}{2}$ ") |
| | In gap | Diameter..... | 480 mm (19") | Top Slide | Width..... |
| | Length | 115 mm (4 $\frac{1}{2}$ ") | Travel | | 92 mm (3 $\frac{5}{8}$ ") |
| Spindle | Bored to Pass..... | 38 mm \varnothing (1 $\frac{1}{2}$ " \varnothing) | Tool | Max. Section | 16 \times 20 mm (5" \times $\frac{3}{4}$ ") |
| | Nose | No. 4-D1 Camlock | Tailstock | Quill – Diameter | 42 mm (1 $\frac{3}{8}$ ") |
| | Morse Taper in Nose..... | No. 5 | | – Travel | 110 mm (4 $\frac{3}{8}$ ") |
| in Bush..... | No. 3 | – Morse Taper | | No. 3 | |
| Speeds | Number | 12 | Weight | Set-Over | \pm 12 mm (\pm 1/2") |
| | Progression Ratio..... | 1.46 | | Model M325 | |
| Motor | Range | 40 to 2500 r.p.m. | 630 mm (25") Cts..... | 583 kg (1288 lb) | |
| | (1500 r.p.m. @ 50 Hz.)..... | 2.2 kW. 3 h.p. | Model M340 | | |
| Leadscrew | Diameter | 28 mm (1 $\frac{1}{8}$ ") | 1000 mm (40") Cts..... | 685 kg (1512 lb) | |
| | Thread | 6 mm pitch or 4 T.P.I. | | | |
| Threads | 39 Metric Pitches..... | from 0.2 to 14 mm Pitch | | | |
| | 35 English Pitches | from 2 to 56 T.P.I. | | | |
| | 18 Module Pitches | from 0.3 to 3.5 MOD. | | | |
| | 18 Diametral Pitches | from 8 to 56 D.P. | | | |

standard equipment

Single Toolpost
Work Driver Plate
No. 5/3 Morse Centre Bush
2 No. 3 M.T. Centres
Spanners, Keys and Oil Gun
Machine Manual
& Standard Inspection Certificate

shipping data

Gross Weight Model M325 762 kg (1680 lb)
Model M340 889 kg (1960 lb)

Packing Case
Dimensions Model M325 1700 \times 940 \times 1470 mm
(67" \times 37" \times 58")
Model M340 2080 \times 940 \times 1470 mm
(82" \times 37" \times 58")

headstock

12 spindle speeds in geometric progression from 40 to 2500 r.p.m.

Transmission gears are of alloy steel – induction hardened and Reishauer ground with the casting itself rigidly located on the bed vee-way.

- Speed selection is made through two 'push & turn' Safety levers against a direct reading speed chart.
- The exceptionally stiff spindle is mounted in Gamet opposed thrust precision taper roller bearings, is bored to pass 38 mm (1½") diameter, and supplied with a 4" D1 Camlock nose for minimum overhang and quick, safe mounting.

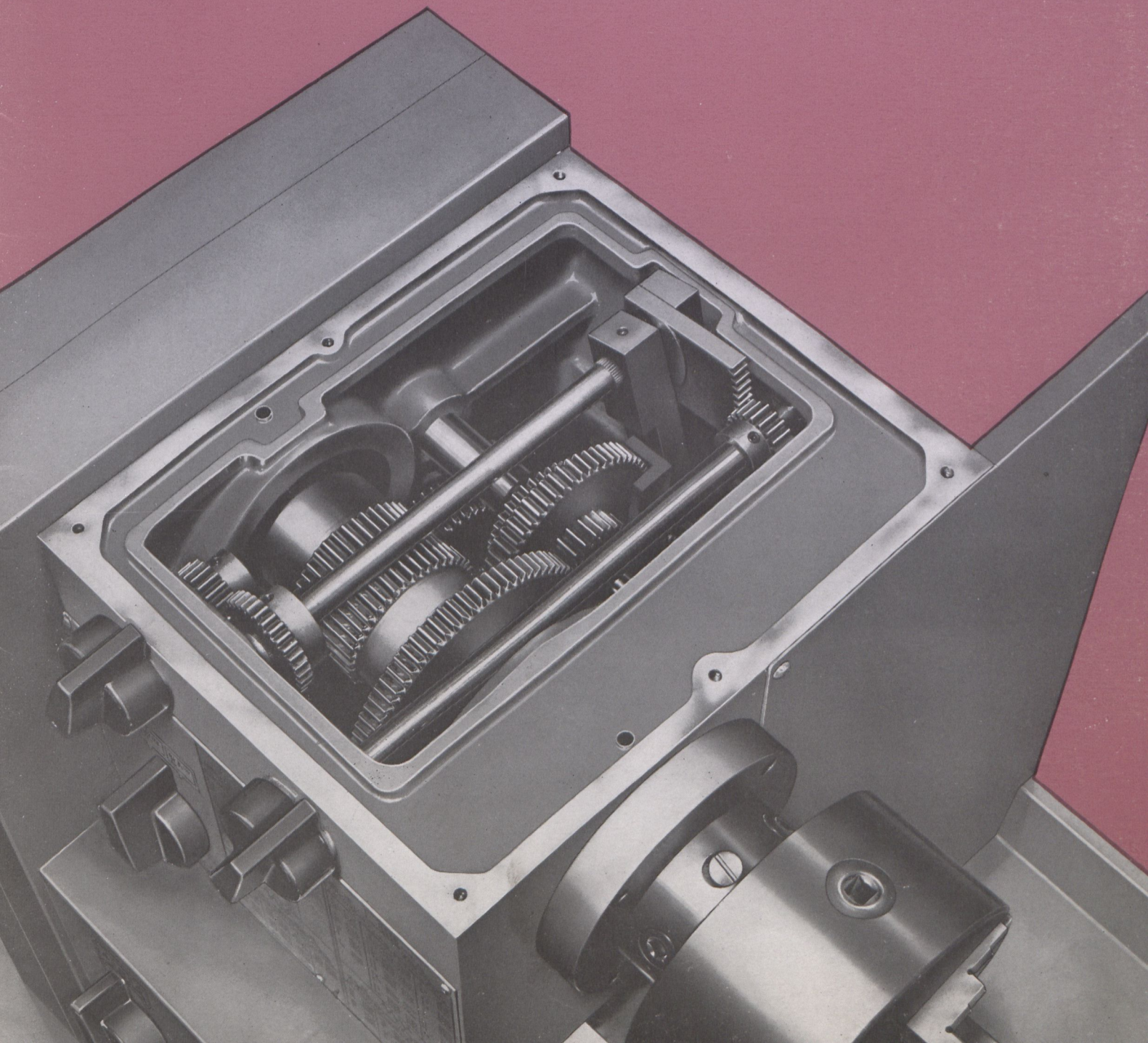

universal gearbox

This rigid one piece cast-iron unit is totally enclosed and splash lubricated.

Induction hardened gears provide a comprehensive range of metric, English, Module and D.P. threads, selections being made through 3 levers and an 8 position rotary dial.

Feed selections automatically disengage the lead screw drive and the central selector lever provides a useful feed 'half and double' feature.

- Independent torque limiting clutches on both leadscrew and feedshaft give protection against accidental overload.

bed and base

The massive section bed, designed for rear swarf disposal is rigidly cross braced and utilizes a separate 70° inverted vee-way for saddle and tailstock alignments.

All bearing surfaces are induction hardened and precision form ground.

The bed is securely bolted to a heavy gauge one piece steel cabinet-base, ensuring a particularly rigid integral structure capable of containing the heaviest of cutting forces.

A full length coolant/swarf tray and capacious lockable tool cupboard are built in.

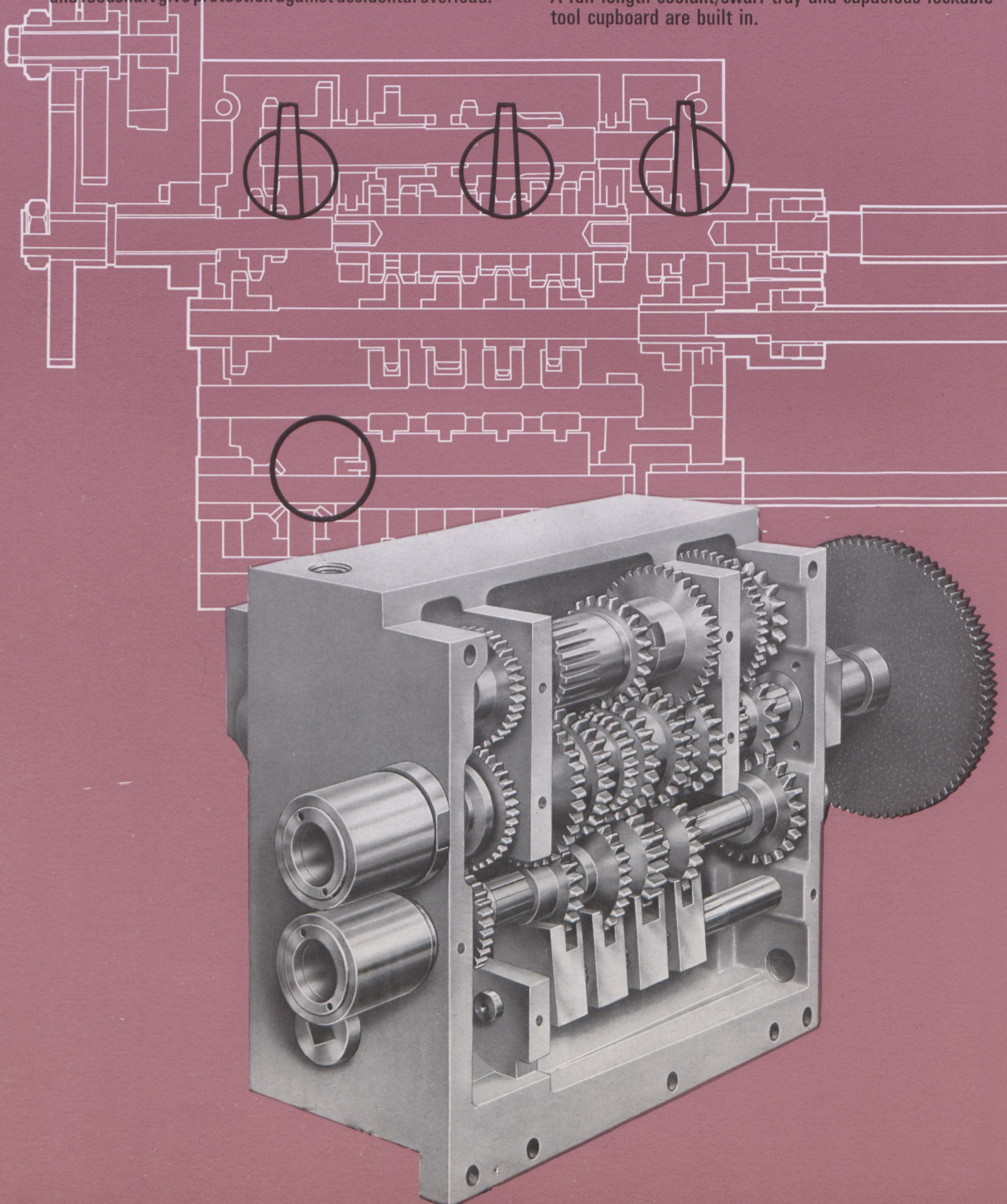

end drive

The basic feed and screw-cutting ranges may readily be extended using the change-wheels supplied. Non-metallic intermediate wheels are incorporated for noise-free running.

- Misuse is prevented by an electrical cut out switch which stops the machine on removal of the end guard

electrical equipment

2.2 kW (3 h.p.) totally enclosed fan cooled main drive motor mounted on bed.

- The electrical enclosure (built into the left hand end of the base) is accessible only through a hinged cover and protected by a mechanically interlocked isolating switch which is padlockable in the off position.
- A low voltage (110 volts) control circuit is employed and a 'no-voltage' protective relay prevents accidental re-starting of the machine following an interruption of supply. Spindle starting is by direct on-line switching through forward and reverse contactors. All external wiring is housed in armoured pvc sheathed conduit and the electrical equipment as a whole conforms to the relevant statutory requirements.

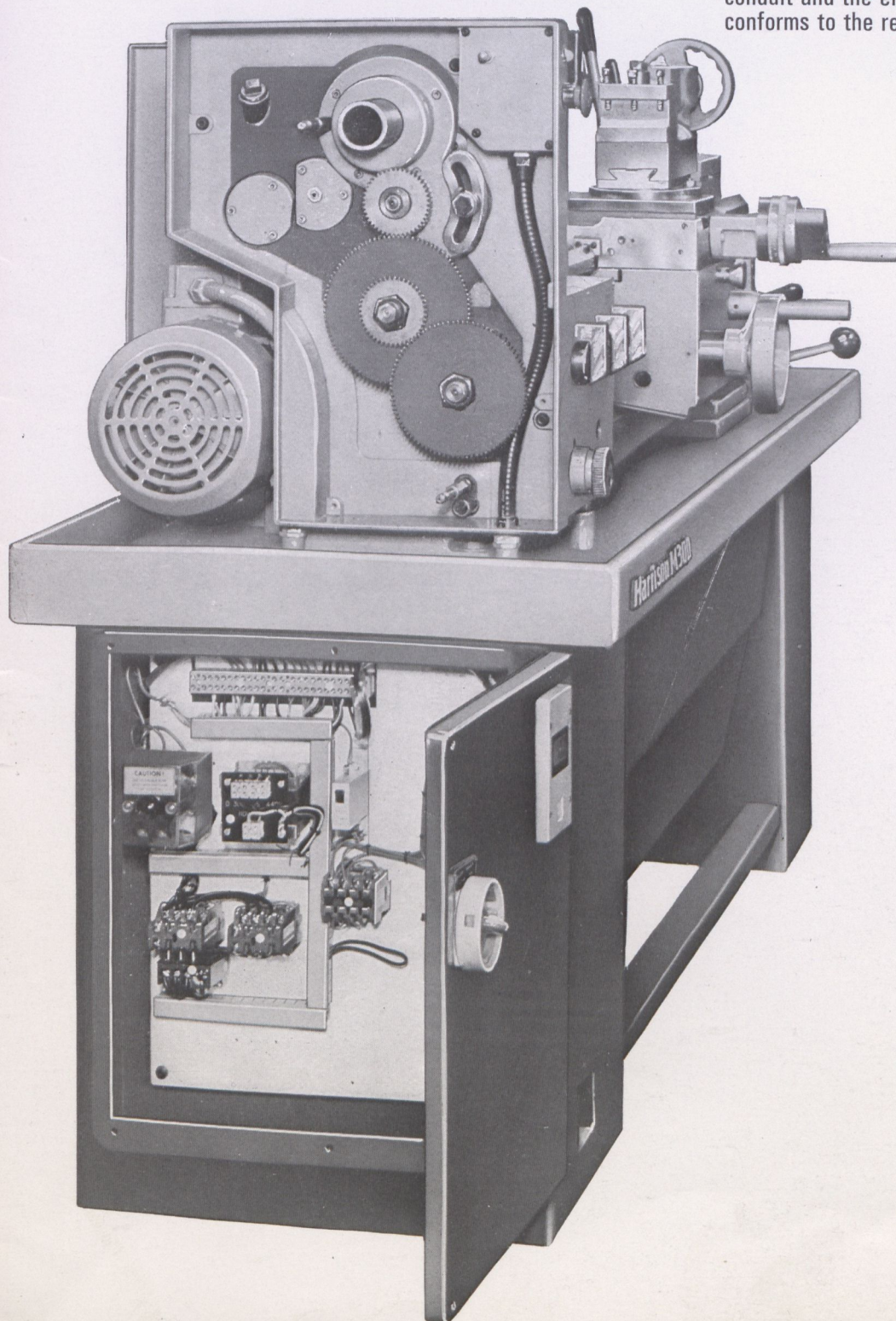

controls

Form, action and position of the controls along with the displayed data format, has been ergonomically determined.

Symbols used are based on International standards.

- Spindle Control (forward – stop – reverse) is through a gated third rod lever mounted on the apron and a powerful full length foot brake is provided.
- A mushroom headed emergency stop button and 'supply-on' lamp are mounted at optimum operator level.

saddle/carriage and slides

Full length cross-slide with external dovetail for quick attachment of rear mounting accessories.

Slide locking clamps and simply operated strip adjusters are incorporated in both saddle and slides. Large diameter micrometer dials – direct reading for diameter on cross-slide.

Anti-backlash cross-slide nut, bedway wipers and centralised lubrication from hand pump mounted in apron are fitted as standard.



apron

Cast iron unit, totally enclosed and splash lubricated. Double half-nut assembly for maximum life and screw-cutting accuracy.

- Drop-out worm feed control is mechanically interlocked with thread cutting lever to prevent simultaneous engagement.
- Disengaging handwheel and thread indicator dial supplied as standard.

tailstock

Extra large quill – accommodates No. 3 morse taper with tang-drive and drift-slot.

Tool ejection, graduated quill, ball thrust bearing, quick cam action clamps and provision for simple set-over adjustment are built-in features whilst a micrometer dial and bed-way wipers are supplied as standard.

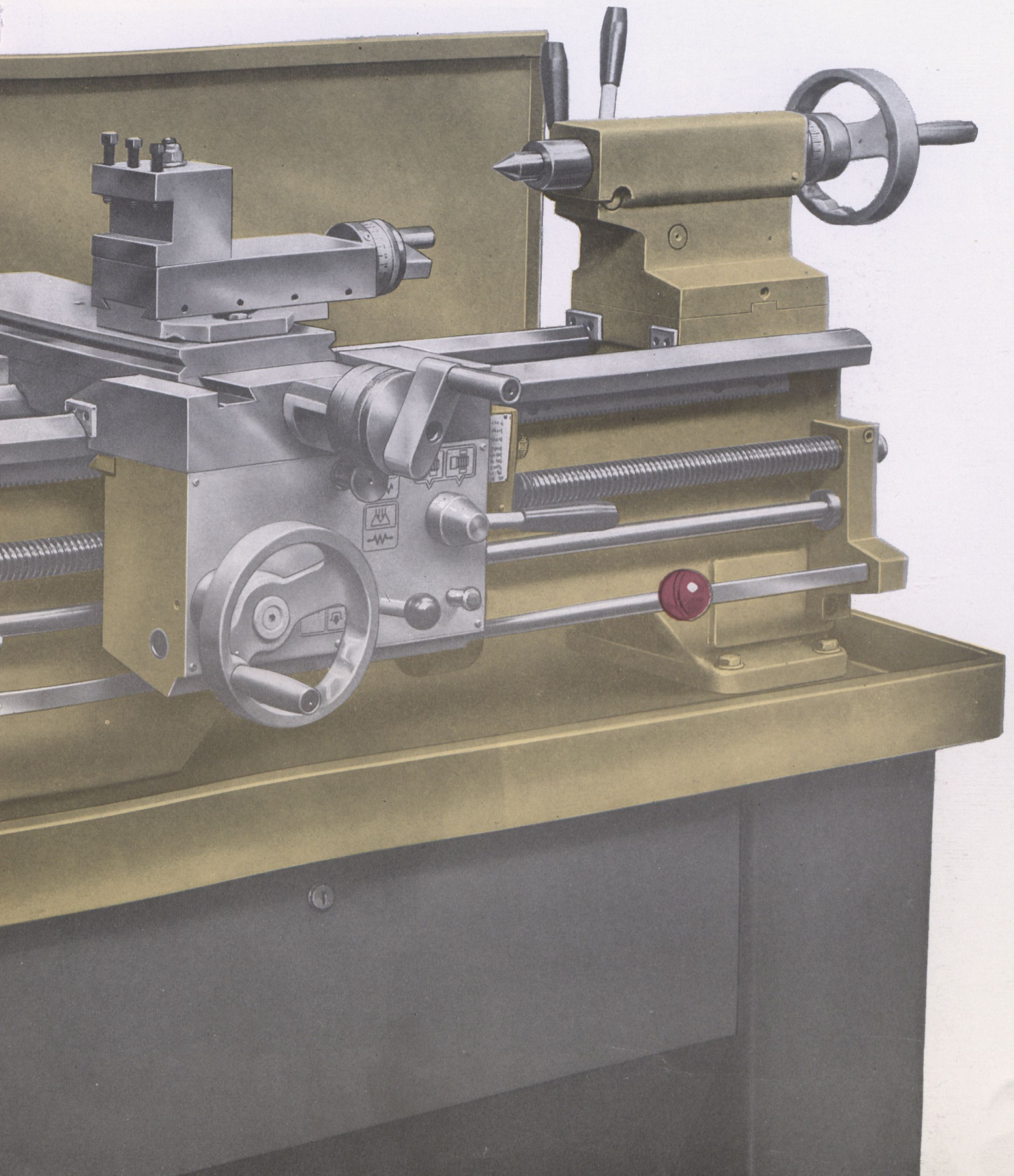

additional equipment
available for the

Harrison M300

The comprehensive range of equipment available for the M300 Lathe provides for an almost unlimited extension to its versatility and production capacity.

Each item listed is either specially selected or specifically designed to match the exacting standards of the machine itself and may be fitted easily to machines already in service.

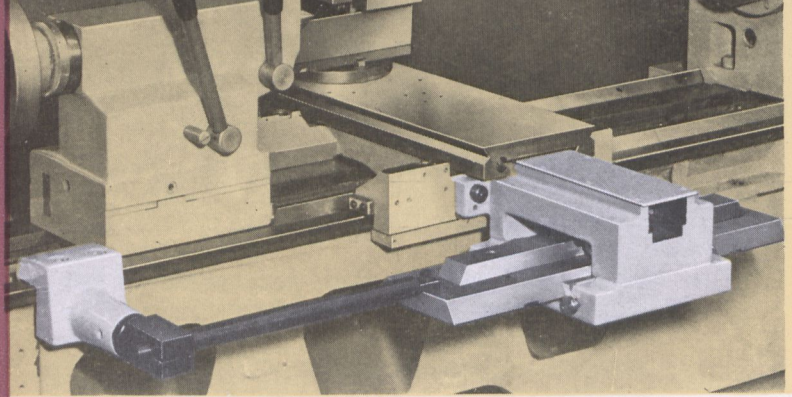

Taper Turning Attachment

Provides for a maximum included angle of 20° to be turned over any length of 250 mm (10") between the working centres.

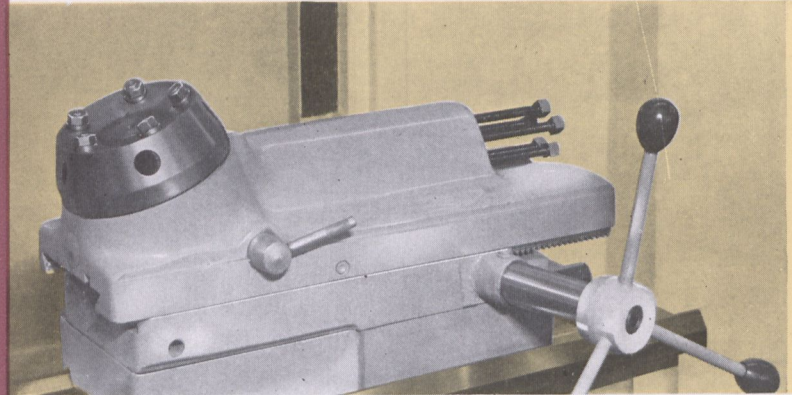

Bed Capstan Unit

Has a 114 mm (4½") stroke, 5 station hand operated slide and built in self indexing stop drum.

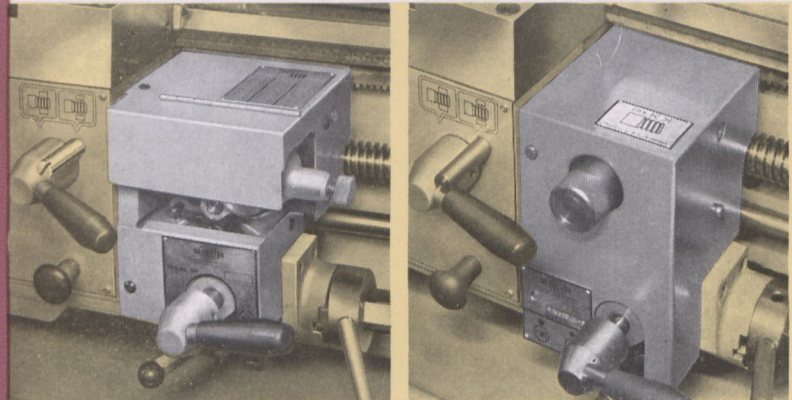

High Speed Threadcutting Attachments

Mechanically synchronize nut engagement positions and disengage on a stop bar, permitting high spindle speeds for rapid confident threadcutting.

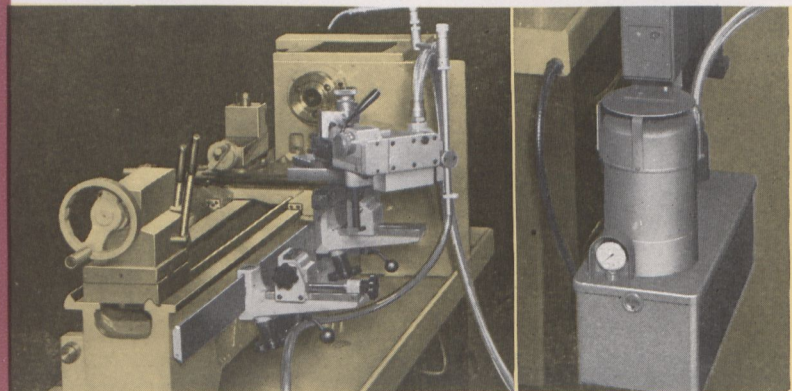

Hydraulic Copying Attachment

enables longitudinal copy turning, face copy turning, copy boring and rapid thread-cutting to be carried out with a minimum of setting-up time.

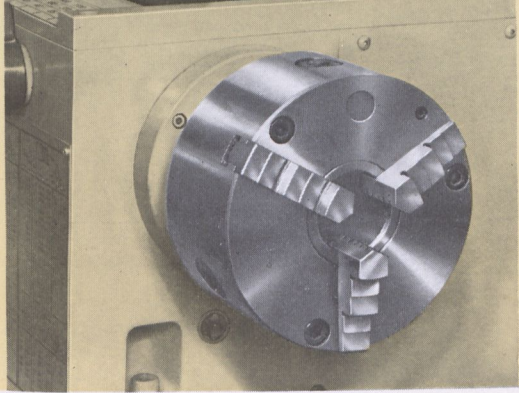

3-jaw Self Centring Chuck

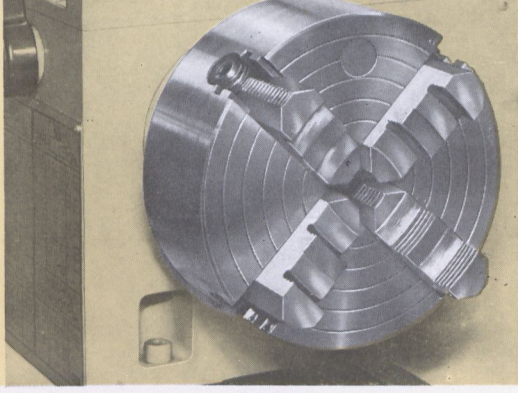

4-jaw Independent Chuck

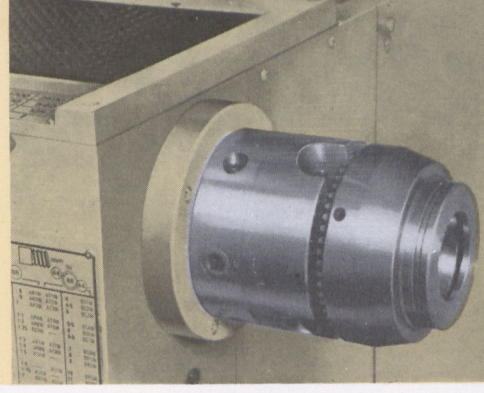

Key operated Collet Chuck

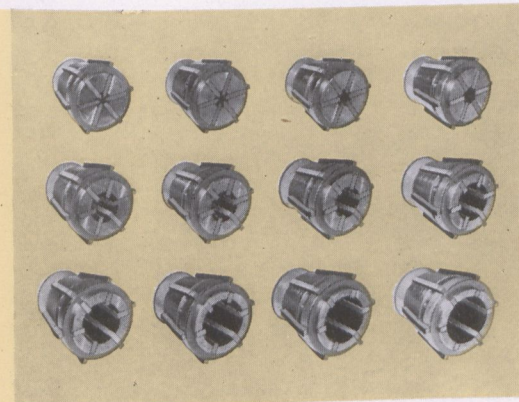

Set of 12 Collets

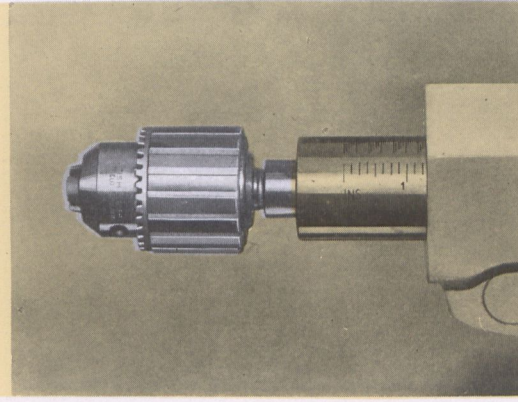

12.7 mm ($\frac{1}{2}$ ") \varnothing cap. Drill Chuck

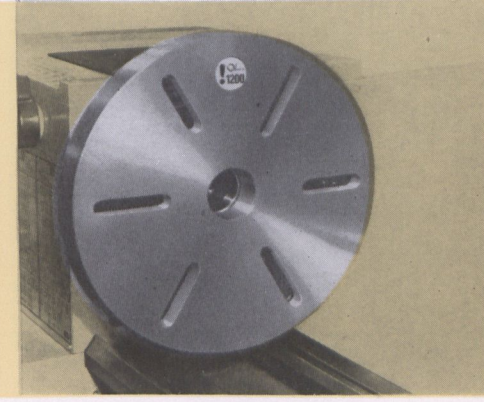

300 mm (12") dia. Faceplate

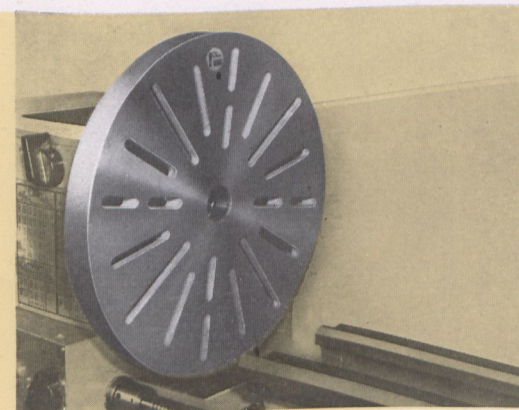

460 mm (18") dia. Faceplate

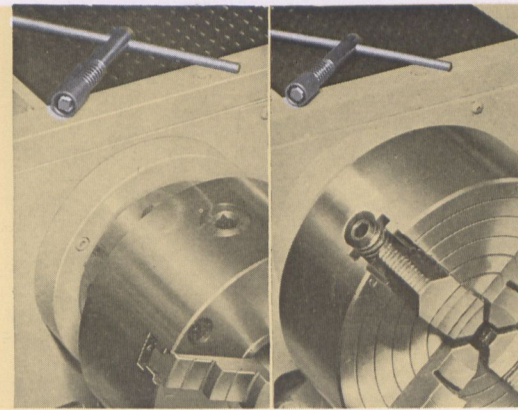

Safety Chuck Keys

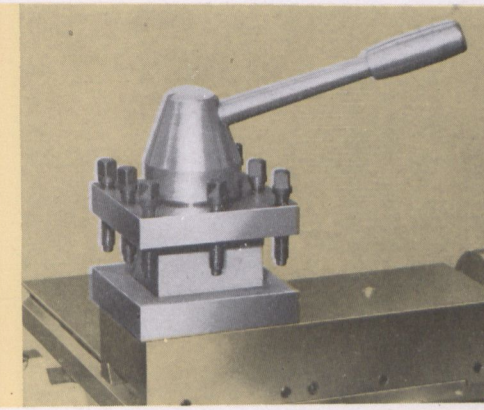

Fourway Hand Indexing Turret

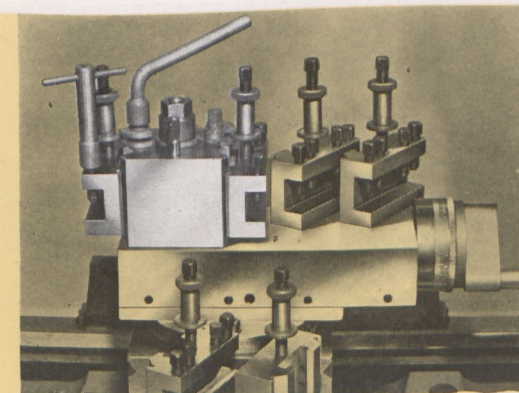

Quick Change Toolpost

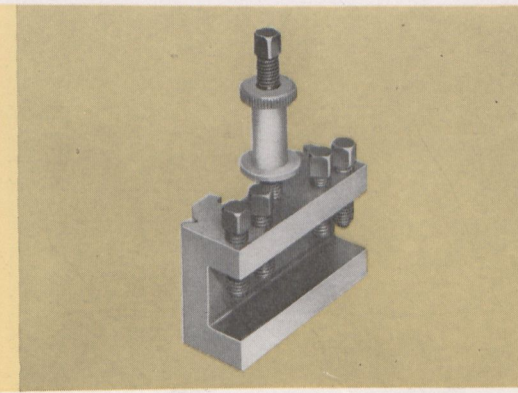

Additional Quick Change Toolholders

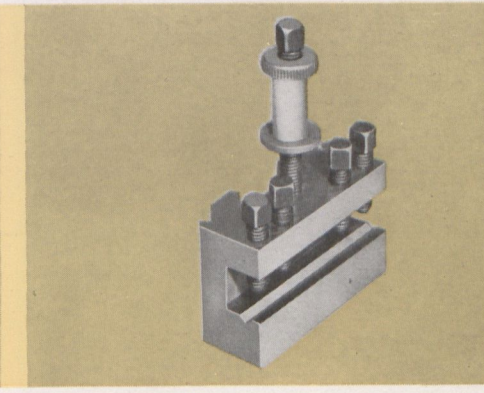

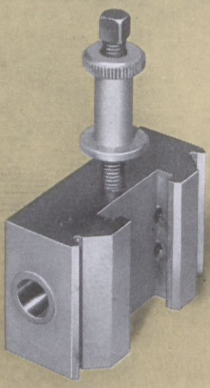

Additional Quick Change Toolholders

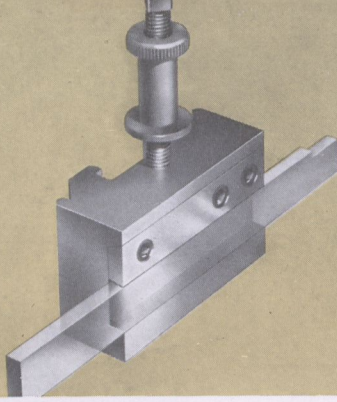

Rear Slide Raiser-Block

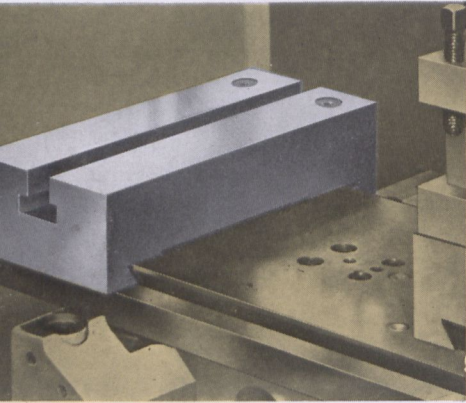
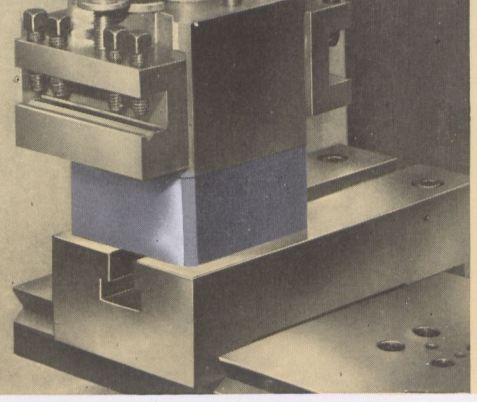

Auxiliary rear slide

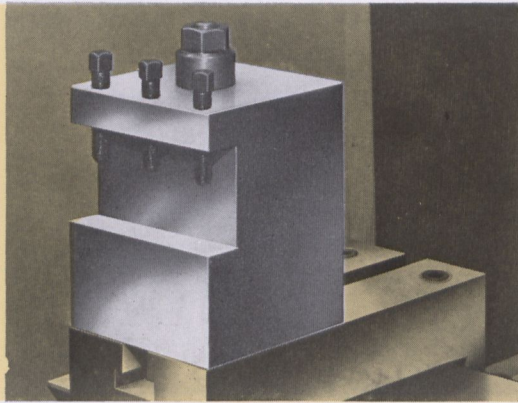

Single Rear toolpost

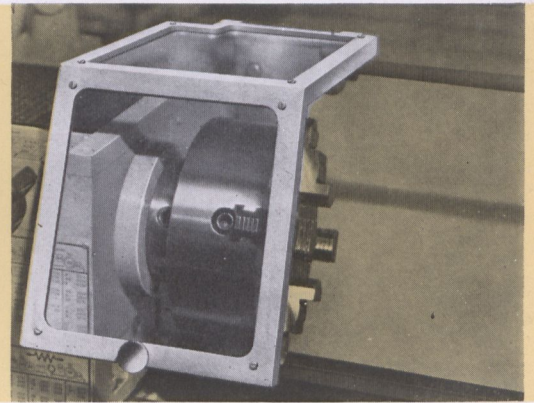

Headstock Chip Guard

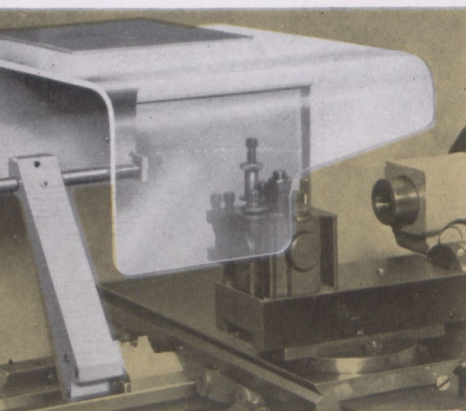

Saddle Chip Guard

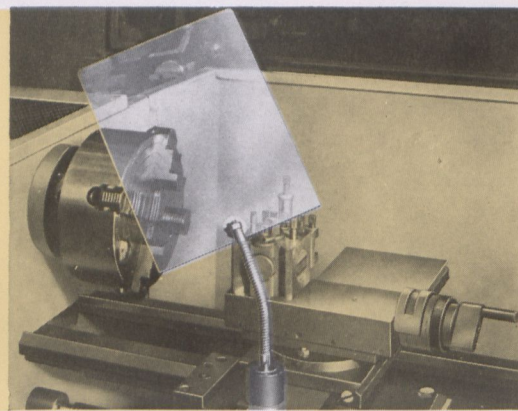

Magnetic Based Chip Guard

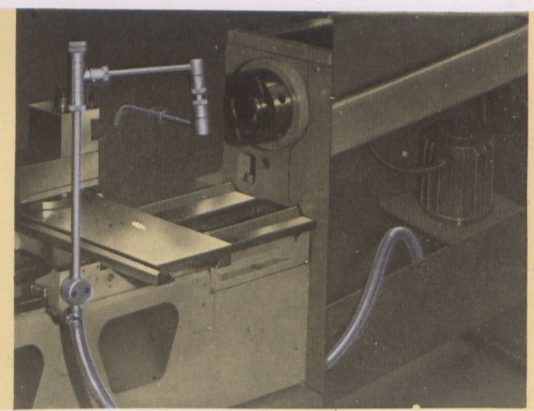

Coolant Pump, Tank & Fittings

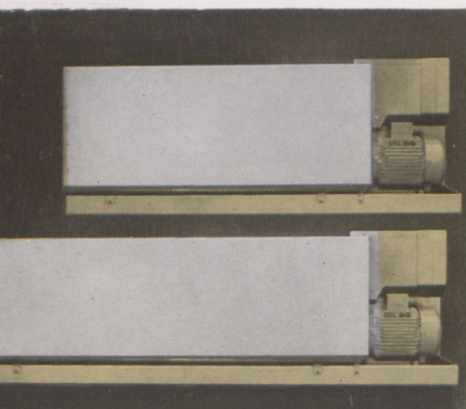

Rear Splash Guards



Low Voltage Machine Lighting

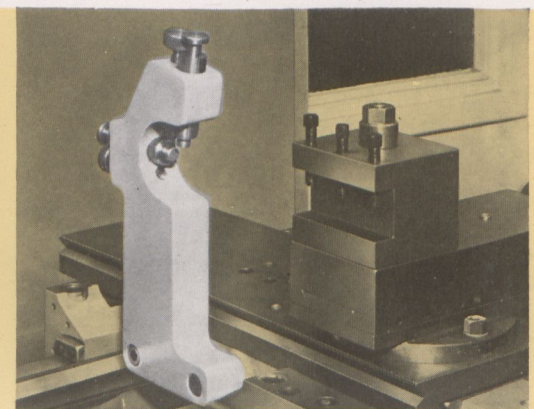

Two Point Travelling Steady

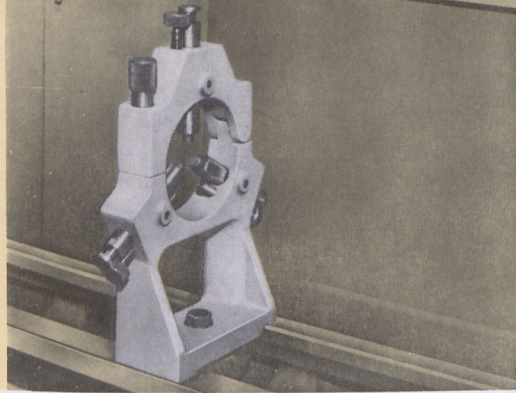

Three Point Stationary Steady

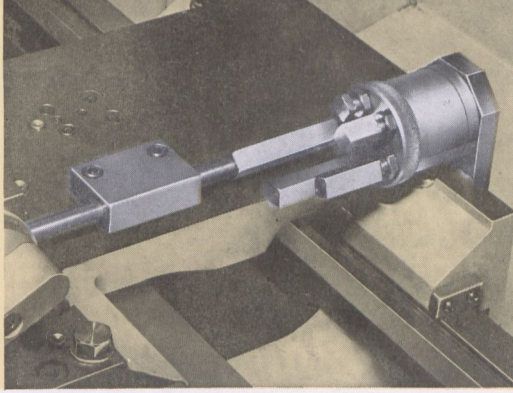

5 Position Cross Slide Stop

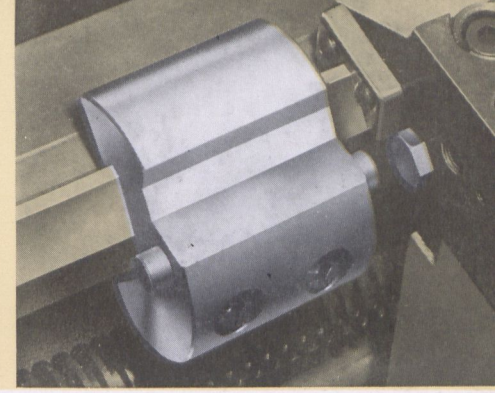

Single Saddle Stop

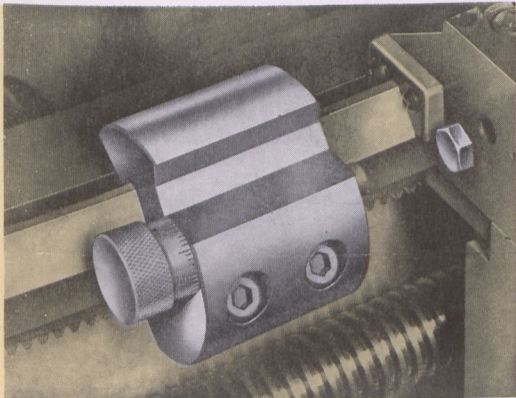

Micrometer Saddle Stop

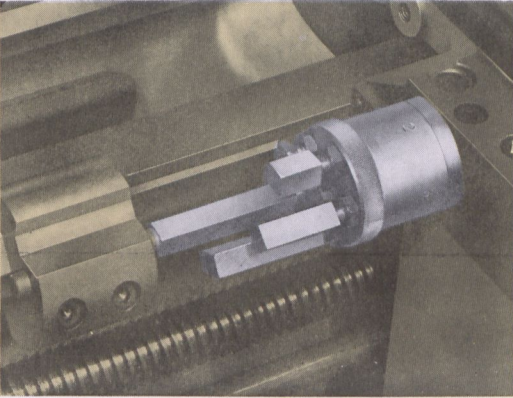

5 Position Saddle Stop

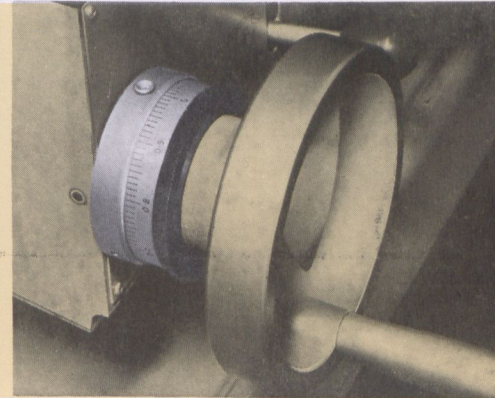

Apron Handwheel Dial
Metric or English

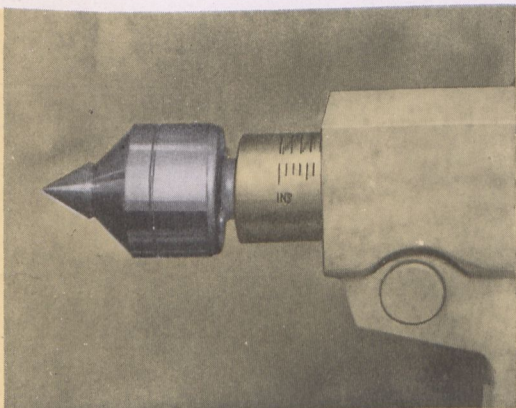

Rotating Tailstock Centre

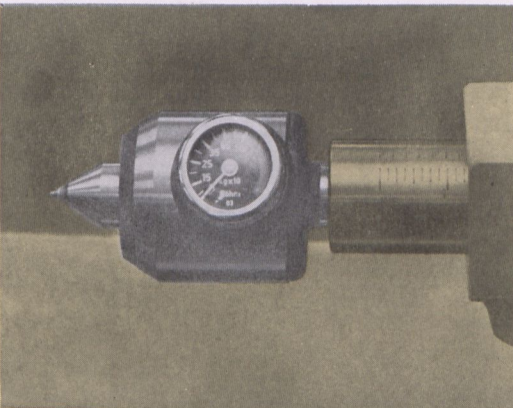

Pressure Gauge Rotating Centre

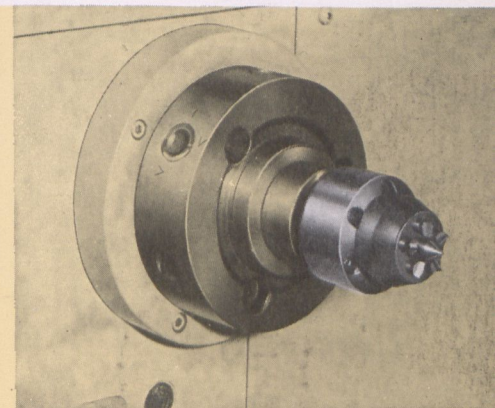

Face Driving Centre

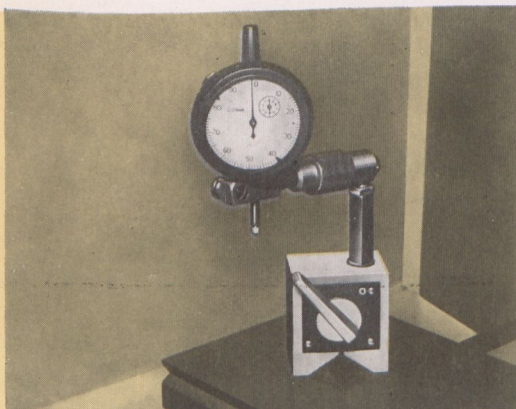

Magnetic Based Dial Indicator
Metric or English

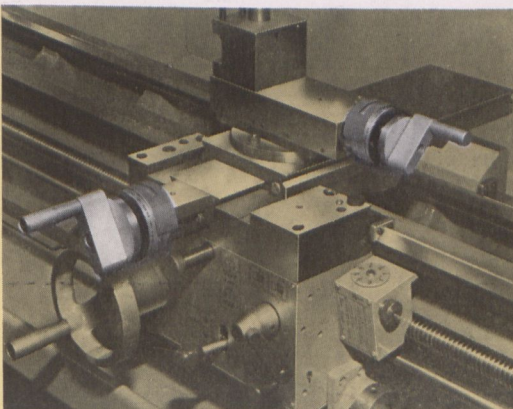

Dual Reading Metric
or English Dials

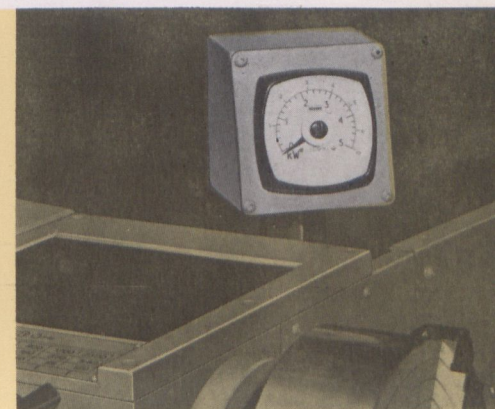

Dynamometer Wattmeter



T.S. Harrison & Sons Ltd.

Union Street, Heckmondwike,
Yorkshire, England, WF16 0HN

Telephone: 0924-403751/6 Telegrams: Harrison, Heckmondwike Telex: 55217

